

Fisher™ EW Series (EWD/EWS/EWT) Sliding-Stem Control Valves through NPS 12x8

Fisher EW Series easy-e™ valves (figures 1, 2, 3, and 4) feature large internal cavities with expanded end connections and a variety of unbalanced and balanced plug designs. Sizes available from NPS 4x2⁽¹⁾ through 12x8. These combinations provide good fluid control in economical, high-capacity valve bodies that keep valve outlet velocities within practical limits.

These valves meet a variety of service requirements, such as power plants where oversized piping is used to limit fluid flow velocity. They also perform well in noise abatement applications; for example, high-pressure gas reducing stations where sonic velocities are often encountered at the outlet of conventional valve bodies.

The Fisher EW product line is available for a wide range of applications, including sulfide and chloride stress-cracking environments common to the oil and gas production industries. To discuss available constructions, contact your [Emerson sales office](#) and include the applicable codes and standards required for these environments.



W2777-1

The easy-e Valve Family

EW Series valves are part of the versatile easy-e family of Fisher industrial control valves. easy-e valves share the following characteristics:

- Multiple trim material choices
- Trim temperature capability with metal seats standard to 427°C (800°F)
- Interchangeable, restricted-capacity trims and full-size trims to match variable process flow demands

- Different cage/plug styles that provide particular flow characteristics for highly-specialized applications. The standard cage comes in three different flow characteristics:
 - quick-opening
 - linear
 - equal percentage
- Cavitrol™ III cages are available to eliminate cavitation damage and Whisper Trim™ III cages are available to help attenuate aerodynamic noise.
- 316 stainless steel packing box parts are standard (including packing flange, studs, and nuts)

The temperature limits of EWT valves can be extended above 232°C (450°F) by using PEEK

(PolyEtherEtherKetone) anti-extrusion rings in combination with a spring-loaded PTFE seal. The PEEK anti-extrusion rings expand to close off the clearance gap between the plug and the cage where the PTFE seal may extrude at high temperatures and pressures. The temperature limits are extended to 316°C (600°F) for non-oxidizing service and to 260°C (500°F) for oxidizing service.

Note

Refer to Fisher Bulletin 51.1:EWN, EWN Series valves with Whisper Trim III cages ([D100024X012](#)) for further information.

Note

Refer to Fisher Bulletin 80.3:010, WhisperFlo™ Aerodynamic Noise Attenuation Trim ([D102362X012](#)) for further information.

Features

- **Compliance with the Clean Air Act**— ENVIRO-SEAL™ packing systems provide an improved stem seal to help prevent the loss of valuable or hazardous process fluid. The ENVIRO-SEAL packing systems feature PTFE or Graphite ULF packing with live-loading for reduced packing maintenance.
- **Noise Attenuation**—In an EW Series valve, noise produced by high flow rates and large pressure drops can be reduced by up to 18 dbA with a Whisper Trim I cage, by up to 30 dbA with a Whisper Trim III cage, and by up to 40 dbA with a WhisperFlo cage.

- **Piping Economy**—Expanded end connections of EW Series valve bodies may reduce the need for line swages while accommodating oversized piping arrangements used to limit fluid flow velocities.
- **Temperature Compensation**—On designs with the seat ring threaded into the valve body (figure 4), the hung cage feature helps reduce gasketing problems caused by thermal expansion and contraction of long parts, such as the cage assembly.
- **Standard Trim Parts across the easy-e product line**—Included are FGM gaskets, packing flange, studs, and nuts.
- **High-Temperature, Class IV or Class V Shutoff**—Optional multiple piston rings (figure 14) for EWD and EWD-1 valve bodies permit Class IV shutoff up to 593°C (1100°F). Use of C-seal trim for EWD (see figure 5) permits Class V shutoff up to 593°C (1100°F).

- **Increased Pressure/Temperature Ratings**—NPS 12x8 CL900 EW Series valve bodies with butt welding end connections are capable of increased ASME ratings called Intermediate Standard Ratings. The extra strength of the valve body allows these valves to be used where pressures and temperatures exceed Standard Class ratings in ASME B16.34.

See Bulletin 59.1:027, Increased Pressure/ Temperature Ratings for EH and EW Series Steel Valves ([D100076X012](#)) for further information.

- **Sour Service Capability**— Unless otherwise noted, references are to NACE MR0175-2002. Optional materials are available to meet NACE MR0103 and NACE MR0175 / ISO 15156. Material requirements under these standards vary by edition and year of issue; the specific standard must be specified.

Table of Contents

Features	2
Specifications	3
C-seal Trim Description	6
ENVIRO-SEAL and HIGH-SEAL Packing Systems	6
Available Configurations	10

Material Selection Guidelines	10
ANSI/FCI Class VI Shutoff Capabilities	12
Fisher TSO (Tight Shutoff) Trim Capabilities	13
Installation	13
Dimensions	33

Specifications

Valve Body Configurations

See Available Configurations section

Valve Body Sizes

See table 2

End Connection Styles

Flanged: ■ CL150, 300, 600, and 900 raised-face or ring-type joint flanges per ASME B16.5, ■ raised-face per EN 1092-1/B

Buttwelding: Styles per ASME B16.25 schedules that are consistent with ASME B16.34 are Schedule ■ 40 or ■ 80 for all CL300 and 600 valves, Schedule ■ 80 or ■ XXS for NPS 8x6 CL900 valves, or Schedule ■ 80, ■ 100, or ■ 120 for NPS 12x8 CL900 valves

Maximum Inlet Pressures and Temperatures⁽¹⁾

Consistent with applicable ■ CL300, ■ 600⁽²⁾, or ■ 900 pressure/temperature ratings per ASME B16.34 unless limited as follows:

Valves With All Except Cavitrol III or Whisper Trim III Cages: Where limited by individual

pressure/temperature capabilities in figure 8 or 9 or temperature capabilities in table 11, 12, 13, or 20.

Valves With Cavitrol III Cages: Where limited by individual pressure/temperature capabilities in figure 12 or temperature capabilities in table 16 or 20

Valves With Whisper Trim III Cages: Where limited by individual pressure/temperature capabilities in figure 15 or 16 or temperature capabilities in table 18 or 20

Maximum Pressure Drops^(1,3)

Same as maximum inlet pressure for specific construction defined above, except where further limited as follows:

Valves With All Except Cavitrol III or Whisper Trim III Cages: See figure 8 or 9

Valves With Cavitrol III Cages: See figure 12

Valves With Whisper Trim III Cages: 0.999 $\Delta P/P_1$ maximum for levels A1 through D3

Shutoff Classifications Per ANSI/FCI 70-2 and IEC 60534-4

See tables 3 and 4

Construction Materials

Valve, Bonnet, and Bonnet Spacer If Used: ■ WCC carbon steel, ■ LCC carbon steel, ■ WC9 chrome moly steel, ■ CF8M (316 SST), ■ other materials upon request

Valve Plug, Cage, and Metal Seating Parts

Valves With All Except Cavitrol III or Whisper Trim III

Cages: See table 5 or 14

Valves With Cavitrol III Cages: See table 15

Valves With Whisper Trim III Cages: See table 17, 18, or 19

All Other Parts: See table 20

Material Temperature Capabilities⁽¹⁾

Valve Body/Trim Combinations

Valves With All Except Cavitrol III or Whisper Trim III

Cages: See figure 8 or 9 and table 11, 12, or 13

Valves With Cavitrol III Cages: See figure 12 and table 16

Valves With Whisper Trim III Cages: See figure 15 or 16 and table 18

All Other Parts: See table 20

Flow Characteristics

Standard Cages: ■ Quick-opening, ■ linear, or ■ equal percentage

Cavitrol and Whisper Trim Cages: Linear

Flow Directions

Valves with Standard Cages

EWD, EWD-1, EWT, and EWT-1: Normally down⁽⁵⁾

EWS and EWS-1: Normally up⁽⁶⁾

Valves with Cavitrol Cages: Always down⁽⁵⁾

Valves with Whisper Trim III Cages: Always up⁽⁶⁾

Flow Coefficients and Noise Level Prediction

Refer to Fisher Catalog 12

Port Diameters and Maximum Valve Plug Travels

See table 21

- continued -

Specifications (continued)

Yoke Boss and Stem Diameters

See table 21

Typical Bonnet Styles (see table 23)

■ Plain, ■ style 1 cast extension, ■ style 2 cast extension, ■ ENVIRO-SEAL bellows seal bonnet

Packing Arrangements

■ Standard PTFE, ■ Double PTFE, ■ Graphite, ■ ENVIRO-SEAL PTFE, ■ ENVIRO-SEAL Duplex, ■ ENVIRO-SEAL Graphite ULF, ■ HIGH-SEAL

Approximate Weights

See table 22

Optional Safety Instrumented System Classification

EWD, EWD-1, EWT, and EWT-1: SIL3 capable — certified by exida Consulting LLC

Options

■ Lubricator, ■ lubricator/isolating valve, ■ drilled and tapped connection in extension bonnet for leak-off service, ■ valve body drain plug, ■ ENVIRO-SEAL bellows seal bonnet for positive stem sealing of hard-to-handle fluids at temperatures up to 566°C (1000°F), ■ style 3 fabricated extension bonnet made on order to a specific length for cryogenic service, ■ special seismic service bonnet, ■ packings suitable for nuclear service, and ■ forged bonnet for 5 in. (127 mm) yoke boss on NPS 8x6 CL900 valve, ■ Class V shutoff for EWT above 232°C (450°F) using PEEK anti-extrusion rings ■ Class V shutoff for EWD up to 593°C (1100°F) using C-seal trim

1. The pressure/temperature limits in this bulletin and any applicable standard or code limitation should not be exceeded.
 2. Certain bonnet bolting material selections may require a CL600 easy-e valve assembly to be derated. Contact your [Emerson sales office](#) for more information.
 3. Only NPS 12x8 CL900 valve bodies with threaded (-1) seat rings can take full CL900 pressure drops; CL900 valve bodies with clamped (no dash number) seat rings are limited to CL600 pressure drops. Also, there are two different NPS 8x6 CL900 valve bodies, one for use only with Cavitrol III cages and the other for use with all other constructions. An NPS 8x6 CL900 valve body with Cavitrol III cage can take full CL900 pressure drops. For information on other NPS 8x6 constructions that can take full CL900 pressure drops, contact your Emerson Automation Solutions sales office. All other NPS 8x6 constructions are limited to CL600 pressure drops (1440 psid flowing drop) even though installed in a CL900 valve body.
 4. Restriction based on excessive noise if max ΔP/P1 ratio for a given cage level is exceeded.
 5. Down: in through cage and out through seat ring (direction shown in figure 1).
 6. Up: in through seat ring and out through cage as shown in figure 13.

ENVIRO-SEAL Packing System Specifications

Applicable Stem Diameters

■ 19.1 (3/4), ■ 25.4 (1), and ■ 31.8 (1-1/4) diameter valve stems

Maximum Pressure/Temperature Limits⁽¹⁾

To Meet the EPA Fugitive Emission Standard of 100 PPM⁽²⁾
 For ENVIRO-SEAL PTFE and ENVIRO-SEAL Duplex packing systems: full CL300 up to 232°C (450°F)
 For ENVIRO-SEAL Graphite ULF packing system: 1500 psig (104 bar) at 316°C (600°F)

Construction Materials

PTFE Packing Systems:
 Packing Ring and Lower Wiper: PTFE V-ring⁽³⁾
 Male and Female Adaptor Rings: Carbon-filled PTFE

V-ring
 Graphite ULF Packing Systems: Graphite rings
 Anti-Extrusion Washer: Filled PTFE (not required for graphite packing)
 Lantern Ring: S31600 (316 stainless steel) (not required for graphite packing)
 Packing Box Flange: S31600
 Spring: ■ 17-7PH stainless steel, ■ N06600, or ■ S17700
 Packing Follower: S31600 lined with carbon-filled PTFE
 Packing Box Studs: Strain-hardened 316 stainless steel
 Packing Box Nuts: 316 stainless steel SA194 Grade 8M

1. Refer to the valve specifications in this bulletin for pressure/temperature limits of valve parts. Do not exceed the pressure/temperature rating of the valve. Do not exceed any applicable code or standard limitation.
 2. The Environmental Protection Agency (EPA) has set a limit of 100 parts per million (ppm) for fugitive emissions from a valve in selected VOC (Volatile Organic Compound) services.
 3. In vacuum service, it is not necessary to reverse the ENVIRO-SEAL PTFE packing rings.

Figure 1. Fisher EWD Valve with Standard Cage

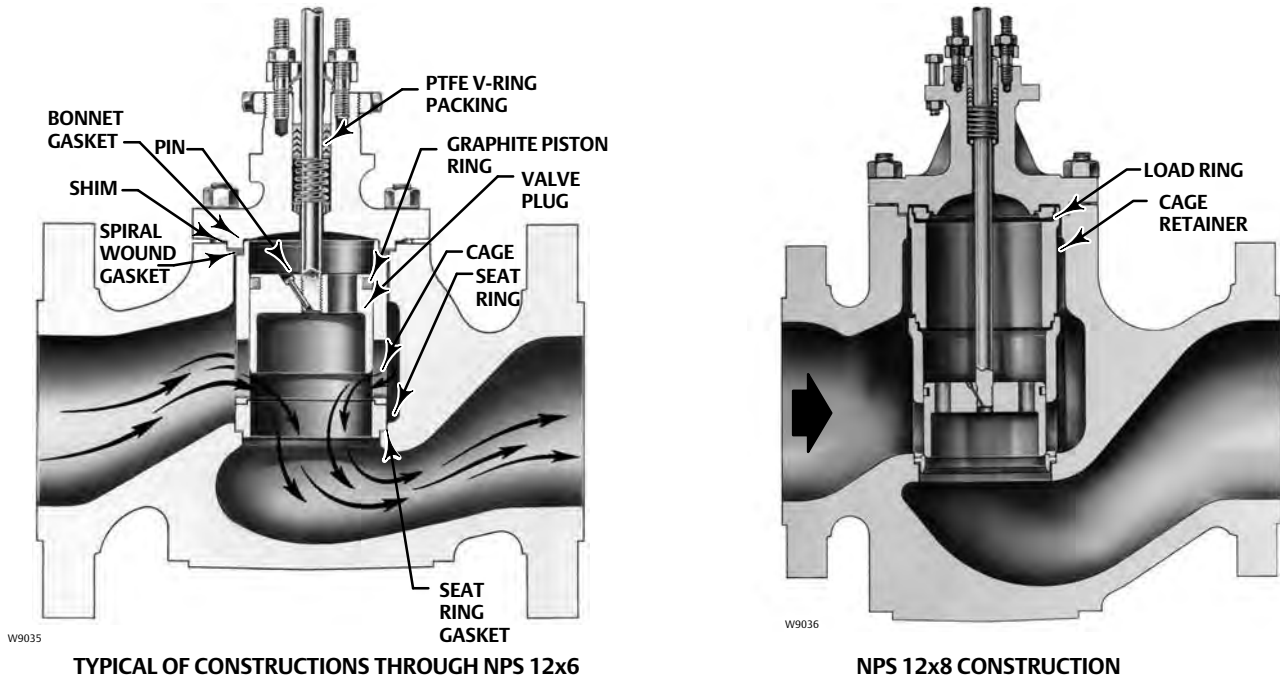

NOTE:
The NPS 10x8 valve is similar in appearance to sizes through NPS 12x6. However, the NPS 10x8 uses the load ring shown for the NPS 12x8. It does not use the cage retainer.

Figure 2. Fisher EWT Trim Details

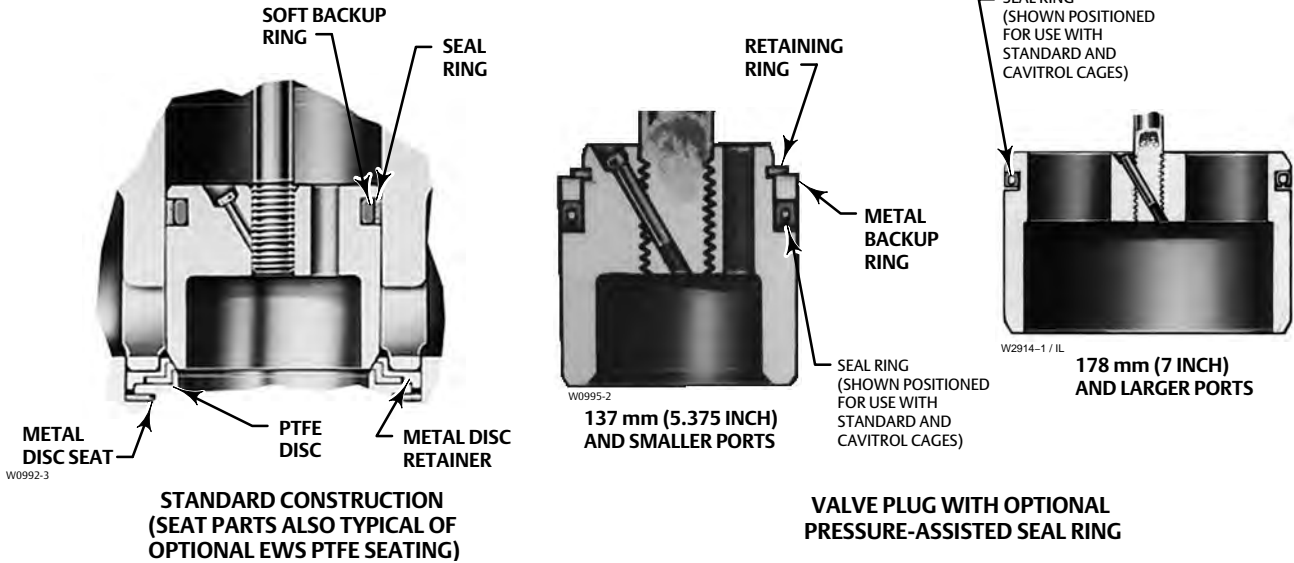
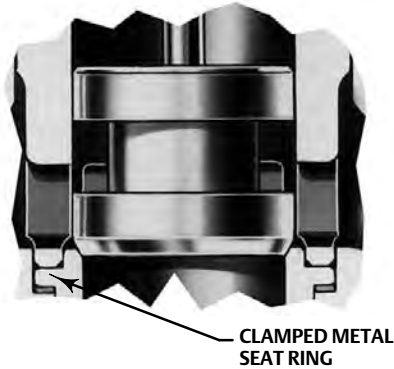

Figure 3. Fisher EWS Trim Details Showing Standard Cage and Seating Construction



C-seal Trim Description

C-seal trim (figure 5) is available for valves with port diameters from 2.875 inches through 8 inches.

With C-seal trim, a balanced valve can achieve high-temperature, Class V shutoff. Because the C-seal plug seal is formed from metal (N07718 nickel alloy) rather than an elastomer, a valve equipped with the C-seal trim can be applied in processes with a fluid temperature of up to 593°C (1100°F).

ENVIRO-SEAL and HIGH-SEAL Packing Systems

Fisher ENVIRO-SEAL and HIGH-SEAL packing systems (figure 17) offer excellent sealing capabilities. These systems easily install in your existing valves or can be purchased with new valves. These systems help you seal your process to conserve valuable process fluid and to protect the environment against the emission of hazardous or polluting fluids. The long-life and reliability of these systems also reduce your maintenance cost and downtime.

For applications requiring compliance with environmental protection regulations, the unique ENVIRO-SEAL packing system and, for hazardous service, the ENVIRO-SEAL bellows seal bonnet (figure 18) are offered. The emission control packing system or seal bonnet keeps emission concentrations below the EPA 100 ppm requirement.

For an excellent stem seal in applications that are not environmentally-sensitive, the HIGH-SEAL Graphite ULF packing system is offered. The HIGH-SEAL packing system provides excellent sealing at pressure/temperature ratings beyond ENVIRO-SEAL limits.

ENVIRO-SEAL packing systems, available with PTFE, Graphite ULF, or Duplex packing, and the HIGH-SEAL Graphite ULF packing system feature live-loading and unique packing-ring arrangements for long-term, consistent sealing performance.

Figure 4. Fisher NPS 12x8 CL900 EWT-1 Valve

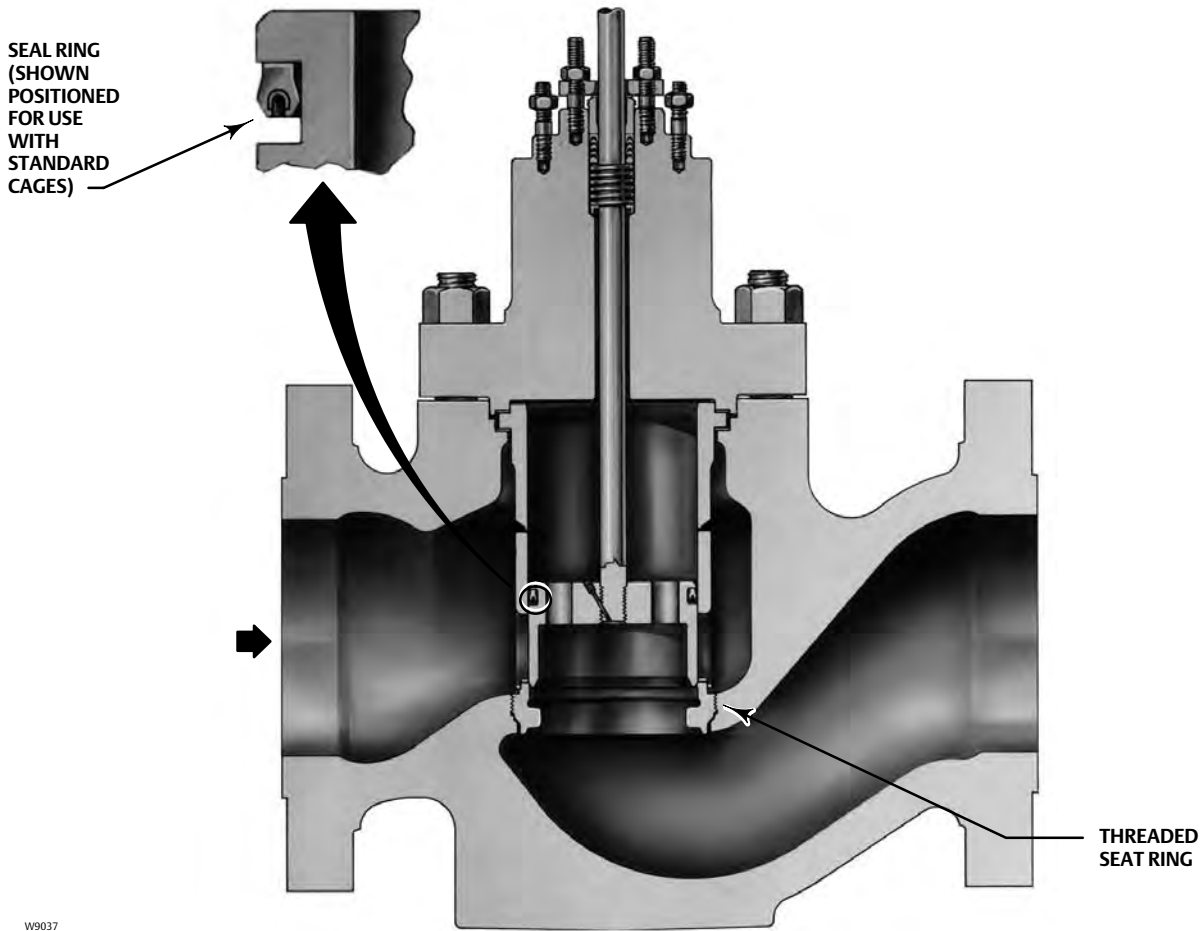

W9037

Figure 5. C-seal Trim

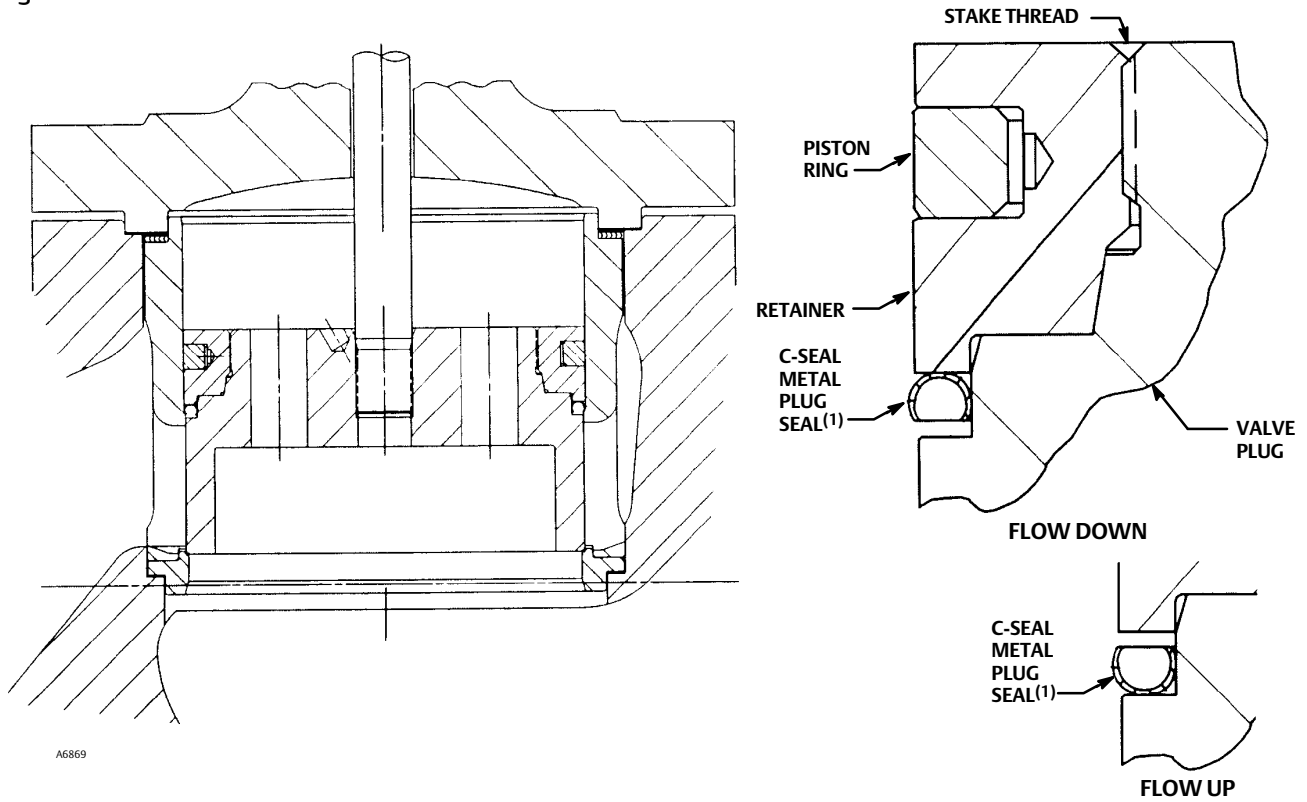

NOTES:

- 1. Reverse the orientation of the C-Seal plug seal proper shutoff when valve is used in a process with different fluid flow direction.

Figure 6. Typical Balanced TSO Trim

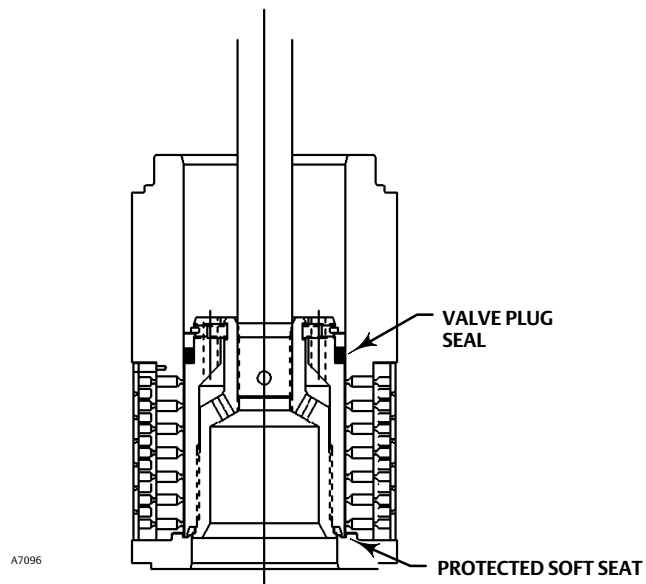
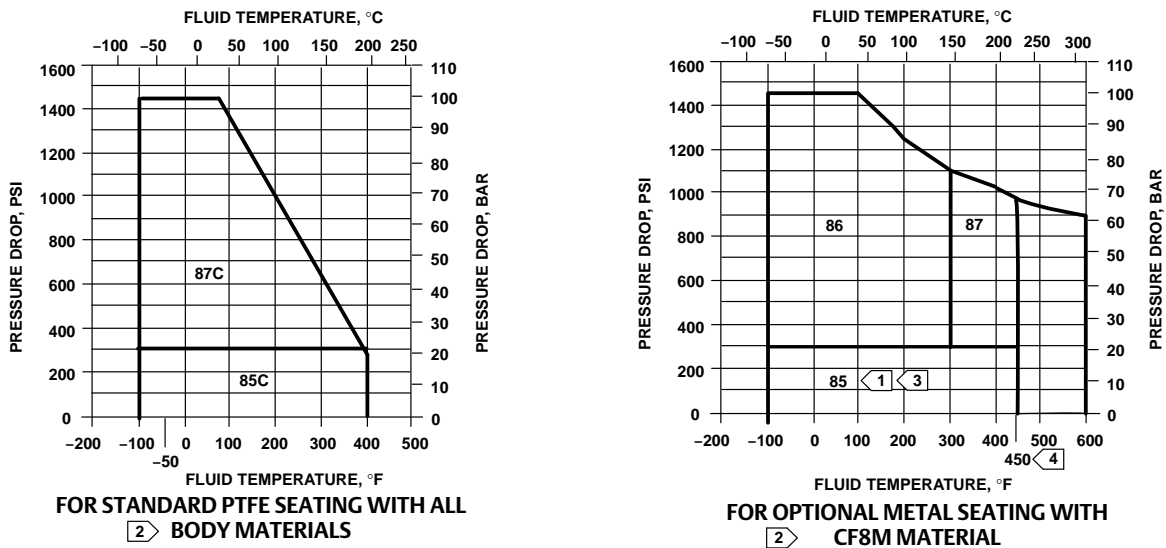

Table 1. Metal Trim Part Materials for Compatibility with NACE MR0175-2002 (Sour Service) Specifications, Environmental Restrictions Apply, Refer to Standard

Trim Designation	Valve Plug	Cage	Seat Ring for Standard Metal Seat Construction	Disk Seat and Retainer for Optional PTFE-Seat Construction	Valve Stem, Packing Follower, Lantern Ring, Packing Box Ring, and Pin	Load Ring ⁽¹⁾
85 ⁽³⁾	S31600	316 SST with electroless nickel coating (ENC)	S31600	---	S20910 (Valve Stem) S31600 (All Other Parts)	N05500
85C ^(2,3)	S31600	316 SST with electroless nickel coating (ENC)	---	S31600		
86 ⁽³⁾	S31600 with seat hard faced with CoCr-A hardfacing alloy	316 SST with electroless nickel coating (ENC)	R30006 (alloy 6)	---		
87	S31600 with seat and guide hard faced with CoCr-A hardfacing alloy	316 SST with electroless nickel coating (ENC)	R30006 (alloy 6)	---		
87C ⁽²⁾	S31600 with seat and guide hard faced with CoCr-A hardfacing alloy	316 SST with electroless nickel coating (ENC)	---	S31600		

1. NPS 10x8 and 12x8 valve body only.
2. 85C and 87C are trims for PTFE-seat constructions in EWS and EWT valves.
3. Not for use with Whisper Trim I with 5-3/8 inch and larger ports.

Figure 7. Typical Trim for NACE MR0175-2002 (Sour Service) (tables 11, 12, and 13 should be used along with these graphs to determine specific limits based on valve size and trim selection)



NOTES:

- 1 Use trim 87 instead of trim 85 for non-lubricating fluids such as superheated steam or dry gasses between 149°C (300°F) and 316°C (600°F).
- 2 Do not exceed the maximum pressure and temperature for the class rating of the body material used, even through the trims shown may have higher capabilities.
- 3 Use trim 85 up to 99 BAR (1440 PSI) with clean dry gas. For process fluids other than clean dry gas, use trim 85 only up to 21 bar (300 PSI).
- 4 Trim 87 temperature limit can be extended above 232°C (450°F) if PEEK anti-extrusion rings and spring-loaded seal ring are used.

Table 2. Available Valve Constructions⁽¹⁾

VALVE	VALVE SIZE ⁽²⁾ , NPS									
	CL150, 300, or 600								CL900	
	4x2	6x4	8x4	8x6	10x6 ⁽³⁾	12x6	10x8	12x8	8x6	12x8
EWD	x	x	x	x	x	x	x	x	x	x
EWD-1	---	---	---	---	---	---	---	---	---	x
EWS	x	x	x	x	x	x	x	x	x	x
EWS-1	---	---	---	---	---	---	---	---	---	x
EWT	x	x	x	x	x	x	x	x	x	x
EWT-1	---	---	---	---	---	---	---	---	---	x

1. X indicates available construction.
2. Two-number valve size designates end connection size x effective trim size.
3. NPS 10x6 has a valve outlet area identical to the NPS 8x6.

Available Configurations

All configurations covered in this bulletin use a single-port, globe-style valve body with cage guiding and push-down-to-close valve plug action. This valve style is combined with different plug styles and either a clamped seat ring (no dash number suffix) or a seat ring threaded into the valve body (-1 suffix).

EWD: Balanced valve plug (figure 1) with clamped seat ring and metal-to-metal seating for all general applications over a wide range of pressure drops and temperatures.

EWD-1: NPS 12x8 CL900 EWD valve body, with threaded seat ring.

EWS: Unbalanced valve plug (figure 3) with clamped seat ring and metal-to-metal or optional metal-to-PTFE seating for all general applications requiring better shutoff capabilities than can be obtained with the EWD valve body.

EWS-1: NPS 12x8 CL900 EWS valve body, with threaded seat ring and metal-to-metal seating.

EWT: Balanced valve plug (figure 2) with metal-to-PTFE seating (for stringent shutoff requirements) standard in all EWT valves (except those with Cavitrol III cages). Metal-to-metal seating for higher temperatures is standard for all EWT valve bodies with Cavitrol III cages and optional for these valves with other cages.

EWT-1: NPS 12x8 CL900 EWT valve body, with threaded seat ring and with metal-to-metal seating (figure 4).

Material Selection Guidelines

Regardless of valve construction, select the valve body/bonnet material from the specifications table, keeping in mind that the valve service conditions cannot exceed the ASME pressure/temperature limitations for the selected valve body. Then, perform steps 1 and 2 under the appropriate valve design heading to complete the selection process.

EWD, EWS, or EWT Valve with all except Cavitrol III or Whisper Trim III Cages

1. Choose a trim combination for the service conditions according to figure 7 and 8, while making sure from tables 1 and 5 that this combination provides the desired trim materials. Then, make sure from table 11, 12, or 13 that the valve body/trim temperature limits are not exceeded.

2. Finally, check in table 20 that packing and other valve parts are available in materials that meet the desired service conditions.

EWD-1, EWS-1, or EWT-1 Valve with Standard Cage

1. Choose a trim combination for the service conditions according to figure 9, while making sure from table 7 that this combination provides the desired trim materials.

2. Finally, check in table 20 that packing and other valve parts are available in materials that meet the desired service conditions.

Table 3. Shutoff Classifications per ANSI/FCI 70-2 and IEC 60534-4

Valve	Seating	Shutoff Class
EWD or EWD-1	Metal	II (standard)
		III (optional for NPS 6x4 through 12x8 valves)
		IV (optional for NPS 6x4 through 12x8 valves with optional multiple graphite piston rings)
EWS or EWS-1	Metal	IV (standard)
		V (optional, consult your Emerson sales office)
EWS	PTFE	VI
EWT with all except Cavitrol III cages	PTFE	V (optional)
	Metal	IV
		V ⁽¹⁾
EWT with 1-stage Cavitrol III cage	Metal	IV (standard)
		V (optional)
EWT with 2-stage Cavitrol III cage or 2- or 3-stage Cavitrol III cage	Metal or PTFE	V
EWT-1	Metal	IV

1. Class V shutoff for EWT requires spring-loaded seal ring, radius-seat plug, and wide-bevel seat ring. Not available with 8-inch port, quick-opening cage. Not available with S31600 (316 SST) valve plug and seat ring (trims 4, 29, 85).

Table 4. C-seal Shutoff Classification

Valve	Valve Size, NPS	Port Diameter, mm (Inches)	Cage Style	ANSI/FCI Leakage Class
EWD (CL300, 600)	6x4x2 1/2	73 (2.875)	Eq. %, Linear, Whisper I, Cav III (2-Stage)	Class V to 593°C (1100°F) [for port diameters from 73 through 203.2 mm (2.875 through 8-inch) with optional C-seal trim]
	6x4	111.1 (4.375)	Eq. %, Linear, Whisper I, Cav III (1-Stage), Whisper III	
	8x4			
	6x4	87.3 (3.4375)	Whisper III	
	8x4			
	8x6	136.5 (5.375)	Cav III (2-Stage), Whisper III	
	12x6			
	10x6 ⁽¹⁾	136.5 (5.375)	Whisper III	
	8x6	177.8 (7)	Eq. %, Linear, Whisper I, Cav III (1-Stage), Whisper III	
	10x6 ⁽¹⁾			
	12x6			
	10x8	203.2 (8)	Eq. %, Linear, Whisper I, Cav III (1-Stage), Whisper III	
12x8				
10x8	177.8 (7)	Whisper III		
12x8				

1. NPS 10x6 has a valve outlet area identical to the NPS 8x6.

EWT Valve with Cavitrol III Cage

1. Choose a trim combination for the service conditions according to figure 12, while making sure from table 15 that this combination provides the desired trim materials. Then, make sure from table 16 that the valve body/trim temperature limits are not exceeded.

2. Finally, check in table 20 that packing and other valve parts are available in materials that meet the desired service conditions.

EWD, EWS, or EWT Valve with Whisper Trim III Cage

1. Choose a trim combination for the service conditions from table 17. Then, make sure from table 18 that the valve body/trim temperature limits are not exceeded.

2. Finally, check in table 20 that packing and other valve parts are available in materials that meet the desired service conditions.

Table 5. Fisher EWD, EWS, and EWT Metal Trim Part Combinations⁽¹⁾ Except for Valves with Cavitrol III or Whisper Trim III Cages

TRIM DESIGNATIONS	VALVE PLUG	CAGE	SEAT	
			Disk Seat, Retainer for PTFE Seat Constructions	Seat Ring for Metal Seat Constructions
1 (standard trim for all valves except EWT and those in CF8M. Trim 57 is standard for EWT. Trim 29 is standard for all valves in CF8M)	S41600 heat treated 17-4 SST HT ⁽¹¹⁾	17-4 SST HT ⁽¹¹⁾	---	S41600 or CA15 ⁽⁵⁾ (S41000) for EWD, EWS CA6NM for EWD-1, EWS-1, EWT-1
3 ⁽¹⁰⁾ and 3H ⁽²⁾⁽⁷⁾	S31600 with seat and guide hard faced with CoCr-A hardfacing alloy	R30006 or R30016 (alloy 6) ⁽³⁾	S31600 with seat hard faced with CoCr-A hardfacing alloy ⁽⁴⁾	S31600 with seat hard faced with CoCr-A hardfacing alloy ⁽⁴⁾
4 ⁽⁶⁾	S31600	17-4 SST HT	S31600	S31600
5 ⁽⁸⁾ and 5H ⁽²⁾⁽⁸⁾	S31600 with seat and guide hard faced with CoCr-A hardfacing alloy	R31233	R30006 disk seat and retainer ⁽⁹⁾	S31600 with seat hard faced with CoCr-A hardfacing alloy ⁽⁴⁾
6 ⁽⁹⁾	S31600 with seat and guide hard faced with CoCr-A hardfacing alloy	S31603 CRPL	R30006 disk seat and retainer ⁽⁹⁾	R30006 (alloy 6)
27	S31600 with seat and guide hard faced with CoCr-A hardfacing alloy	316 SST with electroless nickel coating (ENC)	S31600 with seat hard faced with CoCr-A hardfacing alloy ⁽⁴⁾	S31600 with seat hard faced with CoCr-A hardfacing alloy ⁽⁴⁾
28 ⁽⁶⁾	S31600 with seat hard faced with CoCr-A hardfacing alloy	316 SST with electroless nickel coating (ENC)	S31600 with seat hard faced with CoCr-A hardfacing alloy ⁽⁴⁾	S31600 with seat hard faced with CoCr-A hardfacing alloy ⁽⁴⁾
29 ⁽⁶⁾ (standard for all valves in CF8M)	S31600	316 SST with electroless nickel coating (ENC)	S31600	S31600
37 and 37H ⁽²⁾⁽⁷⁾	S31600 with seat and guide hard faced with CoCr-A hardfacing alloy	17-4 SST HT	S31600 with seat hard faced with CoCr-A hardfacing alloy ⁽⁴⁾	S31600 with seat hard faced with CoCr-A hardfacing alloy ⁽⁴⁾
57 (standard for all EWT valve bodies in all materials except CF8M)	S41600 heat treated 17-4 SST HT ⁽¹¹⁾	17-4 SST HT ⁽¹¹⁾	S31600	---

1. Nonferrous alloy combinations are also available. Consult your [Emerson sales office](#) for details.
 2. Trims 3H, 5H, and 37H have clearances for high-temperature service.
 3. Available only in linear, quick-opening, equal percentage, and Whisper Trim I cages.
 4. Solid cast alloy 6 seat ring is used instead for NPS 4x2, 10x8, and 12x8 valve sizes.
 5. CA15 is used for NPS 8x6 CL900 EWD and EWS.
 6. Not for use with Whisper Trim I with 5-3/8 inch and larger ports.
 7. With C-Seal trim, 3H, and 37H use solid cast Alloy 6 seat ring for NPS 8x4, 10x8, and 12x8 sizes.
 8. Available only for NPS 8x6, 12x6, 10x8, 12x8 sizes Whisper Trim I cages.
 9. Available only for NPS 10x8 and 12x8 Whisper Trim I cages.
 10. For trim 3, upper temperature limited to 316°C (600°F) when used for Whisper Trim I cages.
 11. For NPS 10 x 8 and 12 x 8 sizes with Whisper Trim I cages.

EWD-1, or EWT-1 Valve with Whisper Trim III Cage

1. Choose a trim combination for the service conditions according to figure 15 or 16, while making

sure from table 19 that this combination provides the desired trim materials.

2. Finally, check in table 20 that packing and other valve parts are available in materials that meet the desired service conditions.

ANSI/FCI Class VI Shutoff Capabilities

EWS valves with metal seat constructions and EWT valves with soft seat and metal seat constructions can provide ANSI/FCI Class VI shutoff capabilities. See tables 6 and 7.

Table 6. Class VI Shutoff Availability

Valve	Port Size, Inches	Seat	Minimum Seat Load
EWS	≤ 7	Metal	300 lbs/lineal inch
EWT	≥ 3.4375 ≤ 7	Soft	See Catalog 14
EWT	≥ 3.4375 ≤ 7	Metal	300 lbs/lineal inch

Table 7. Class VI Trim Materials

VALVE	CAGE	VALVE PLUG	SEAT RING	SEAL RING	TRIM TEMPERATURE LIMIT	
					°C	°F
EWS	316 SST/ ENC	S31600/CoCr-A (alloy 6) seat	S31600	NA	Not a limiting factor	
EWT	316 SST / ENC	S31600	S31600/PTFE	UHMWPE ⁽¹⁾ R30003	-29 to 66	-20 to 150
	316 SST / ENC	S31600/CoCr-A seat	S31600	UHMWPE R30003	-101 to 66	-150 to 150
	17-4 SST (17-4PH SST)	S41600	S31600/PTFE	UHMWPE R30003	-29 to 66	-20 to 150
	17-4 SST	S41600	S31600	UHMWPE R30003	-29 to 66	-20 to 150

1. UHMWPE (Ultra High Molecular Weight Polyethylene)

Fisher TSO (Tight Shutoff) Trim Capabilities

See figure 6 and tables 8, 9, and 10. For additional information contact your [Emerson sales office](#).

Table 8. TSO (Tight Shutoff) Leakage Class

Leakage Class	Maximum Leakage	Test Medium	Test Pressure	Test Procedure
TSO (Tight Shutoff)	Valves with TSO trim are factory tested to a more stringent Fisher test requirement of no leakage at time of shipment.	Water	Service ΔP ⁽¹⁾	ANSI/FCI Class V test procedure B

1. Specify service Δ P when ordering.

Table 9. TSO Shutoff Availability

VALVE	CONSTRUCTION
EWT	Std or Cavitrol III trim. Replaceable, protected soft seat

Table 10. Port Diameters, Valve Plug Travel, Yoke Boss Diameters for TSO (Tight Shutoff) Trim

VALVE	TRIM	MAX TRAVEL		YOKE BOSS SIZE		PORT DIAMETER				C _v REDUCTION AT 100% TRAVEL ⁽¹⁾	UNBALANCE AREA
		mm	Inch	mm	Inch	Nominal		Actual TSO			
						mm	Inch	mm	Inch		Inch ²
EWT NPS 6x4	Std	50.8	2	90	3-9/16	111	4.375	106	4.1875	4% (linear) 3% (equal percent)	0.154
EWT NPS 8x6 and 10x6 ⁽²⁾	Std	50.8	2	90 127	3-9/16 5	179	7	173	6.8125	2%	0.30
		102	4	90	3-9/16					2%	

1. This column lists the percent reduction of published maximum C_v of the trim listed in the TRIM column.
2. NPS 10x6 has a valve outlet area identical to the NPS 8x6.

Installation

Unless limited by seismic criteria, the valve body can be installed in any position (as long as sufficient support is provided if a fabricated extension bonnet is used). However, the normal method is with the actuator vertical above the valve, because non-vertical positions may cause uneven trim wear and decreased trim life.

Flow through the valve body must be in the direction indicated by the flow direction arrow on the valve body. Consider installing an upstream strainer, especially if the valve body includes slotted or multihole Whisper Trim or Cavitrol cages.

Dimensions are shown in figure 19.

Figure 8. Typical Trim Used in Fisher EWD, EWS, or EWT Valves Except Those with Cavitrol III or Whisper Trim III Cages (tables 11, 12, and 13 should be used along with these graphs to determine specific limits based on valve size and trim selection)

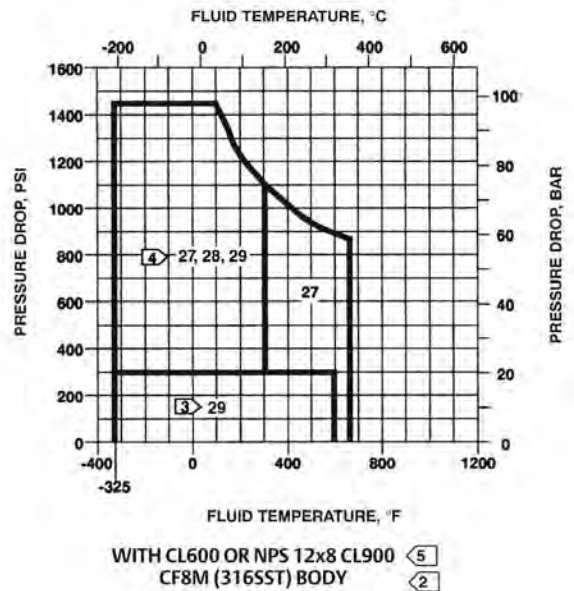
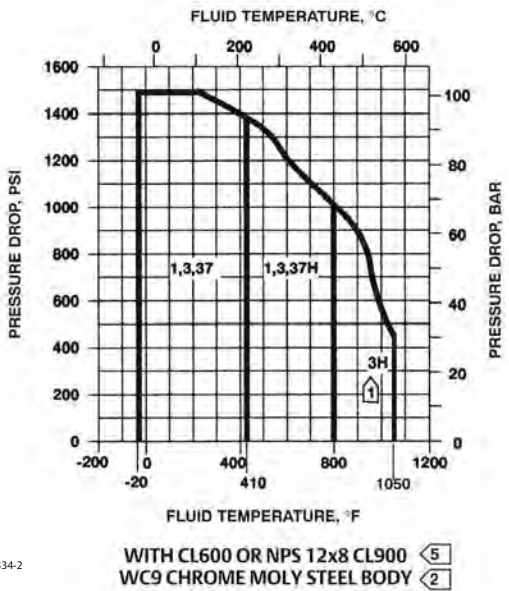
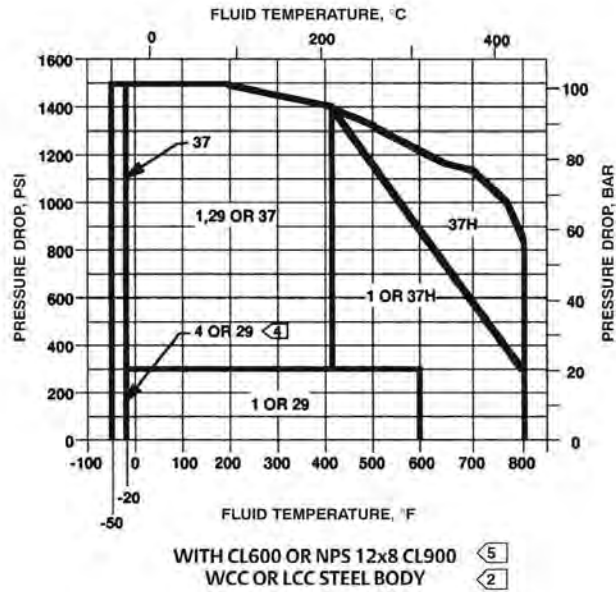
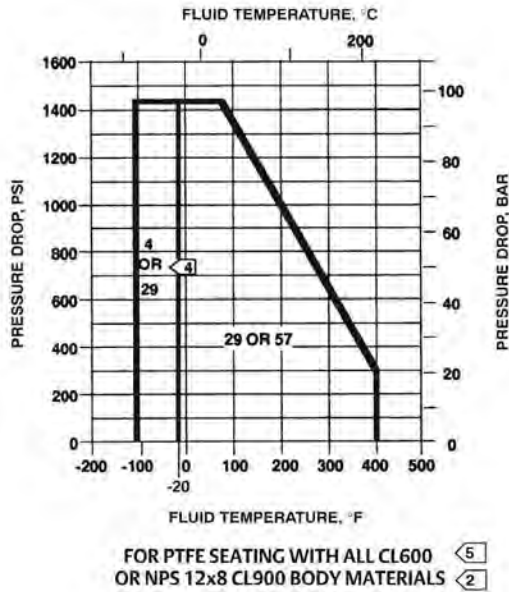

NOTES:

- 1 Be especially careful to specify service temperature if trim 3, 4, or 37 is selected, as different thermal expansion rates require special plug clearances, also, use trim 37H instead of trim 4 for non-lubricating fluids such as superheated steam or dry gasses between 149°C (300°F) AND 316°C (600°F).
- 2 Do not exceed the maximum pressure and temperature for the class rating of the body material used, even through the trims shown may have higher capabilities.
- 3 Use trim 27 instead of trim 29 for non-lubricating fluids such as superheated steam or dry gasses between 149°C (300°F) AND 316°C (600°F).
- 4 Trims 4 AND 29 may be used over 300 PSI only with clean, dry gas.
- 5 EWD, EWS, and EWT NPS 12x8 CL900 limited to CL600 pressure drops. See figure 9 and 10 EWD-1, EWS-1, and EWT-1 for full CL900 NPS 12x8 pressure drops.

Table 11. Valve/Trim Temperature Capabilities⁽¹⁾ for CL300 or 600 Fisher EWD, EWS, and EWT Valves with 2-Inch (51 mm) or 3-Inch (76 mm) Travel (Except those with Cavitol III or Whisper Trim III Cages) (figures 7 and 8 should be used along with this table to determine specific limits based on valve size and trim selection)

VALVE/BONNET MATERIAL	TRIM DESIGNATION FROM TABLE 5	VALVE SIZE, NPS	MATERIAL TEMPERATURE CAPABILITY			
			°C Min	°C Max	°F Min	°F Max
WCC steel	1	4 x 2	-29	399	-20	750
		6 x 4	-29	343	-20	650
		8 x 4	-29	329	-20	625
		8 x 6 or 10 x 6 ⁽³⁾	-29	316	-20	600
		12 x 6	-29	260	-20	500
		12 x 8 or 10 x 8	-29	427	-20	800
	29, 85	4 x 2	-29	316	-20	600
		6 x 4	-29	221	-20	430
		8 x 4	-29	218	-20	425
		8 x 6 or 10 x 6 ⁽³⁾	-29	204	-20	400
12 x 6	-29	174	-20	345		
12 x 8 or 10 x 8	-29	316	-20	600		
5 ⁽⁴⁾	8 x 6, 12 x 6, 10 x 8, or 12 x 8	-29	316	-20	600	
5H ⁽⁴⁾		316	427	600	800	
6 ⁽⁴⁾	10 x 8	-29	316	-20	600	
37	4 x 2 through 12 x 8	-29	210	-20	410	
37H		210	427	410	800	
57		-29	204	-20	400	
LCC steel	1	4 x 2	-29	343	-20	650
		6 x 4	-29	343	-20	650
		8 x 4	-29	329	-20	625
		8 x 6 or 10 x 6 ⁽³⁾	-29	329	-20	625
		12 x 6	-29	260	-20	500
		10 x 8 or 12 x 8	-29	343	-20	650
	29, 85	4 x 2	-46	316	-50	600
		6 x 4	-46	218	-50	425
		8 x 4	-46	218	-50	425
		8 x 6 or 10 x 6 ⁽³⁾	-46	204	-50	400
12 x 6	-46	163	-50	325		
10 x 8 or 12 x 8	-46	316	-50	600		
5 ⁽⁴⁾	8 x 6, 12 x 6, 10 x 8, or 12 x 8	-46	316	-46	600	
6 ⁽⁴⁾	10 x 8	-46	316	-50	600	
37	4 x 2 through 12 x 8	-46	210	-50	410	
37H		210	343	410	650	
57		-29	204	-20	400	

-continued-

Table 11. Valve/Trim Temperature Capabilities⁽¹⁾ for CL300 or 600 Fisher EWD, EWS, and EWT Valves with 2-Inch (51 mm) or 3-Inch (76 mm) Travel (Except those with Cavitrol III or Whisper Trim III Cages) (figures 7 and 8 should be used along with this table to determine specific limits based on valve size and trim selection) (continued)

VALVE/BONNET MATERIAL	TRIM DESIGNATION FROM TABLE 5	VALVE SIZE, NPS	MATERIAL TEMPERATURE CAPABILITY				
			°C Min	°C Max	°F Min	°F Max	
WC9 chrome moly steel	1	4 x 2	-29	399	-20	750	
		6 x 4	-29	343	-20	650	
		8 x 4	-29	329	-20	625	
		8 x 6 or 10 x 6 ⁽³⁾	-29	316	-20	600	
		12 x 6	-29	260	-20	500	
		12 x 8 or 10 x 8	-29	427	-20	800	
	3	4 x 2 through 12 x 8	-29	427 ⁽⁵⁾	-20	800 ⁽⁵⁾	
	3H		427	566	800	1050	
	5 ⁽⁴⁾	8 x 6, 12 x 6, 10 x 8, or 12 x 8	-29	316	-20	600	
	5H ⁽⁴⁾		316	566	600	1050	
	6 ⁽⁴⁾		10 x 8	-29	316	-20	600
	27, 87	4 x 2	4 x 2	-29	343	-20	650
			6 x 4	-29	221	-20	430
			8 x 4	-29	218	-20	425
			8 x 6 or 10 x 6 ⁽³⁾	-29	204	-20	400
			12 x 6	-29	163	-20	325
			12 x 8 or 10 x 8	-29	343	-20	650
		29, 85	4 x 2	4 x 2	-29	316	-20
6 x 4				-29	221	-20	430
8 x 4				-29	218	-20	425
8 x 6 or 10 x 6 ⁽³⁾				-29	204	-20	400
12 x 6				-29	163	-20	325
12 x 8 or 10 x 8				-29	316	-20	600
37	4 x 2 through 12 x 8	-29	210	-20	410		
37H		210	427	410	800		
57		-29	204	-20	400		
LCC steel CF8M (316 SST)	5 ⁽⁴⁾	8 x 6, 12 x 6, 10 x 8, or 12 x 8	-198 ⁽⁴⁾	316 ⁽¹⁾	-325 ⁽⁴⁾	600 ⁽¹⁾	
	6 ⁽⁴⁾	10 x 8	-198 ⁽⁴⁾	316 ⁽¹⁾	-325 ⁽⁴⁾	600 ⁽¹⁾	
	27	4 x 2 through 12 x 8	-198 ⁽²⁾	343	-325 ⁽²⁾	650	
	28		-198 ⁽²⁾	149	-325 ⁽²⁾	300	
	29, 85		-198 ⁽²⁾	316	-325 ⁽²⁾	600	

1. For metal trim parts only.
 2. May be used down to -254°C (-425°F) if manufacturing process includes Charpy Impact test.
 3. NPS 10x6 has a valve outlet area identical to the NPS 8x6.
 4. Available for Whisper Trim I cages.
 5. For Trim 3, upper temperature to 316°C (600°F) when used for Whisper Trim I cages.

Table 12. 4-Inch (102 mm) Travel Whisper Trim I Fisher EWD and EWT Valve Body/Trim Temperature Capabilities⁽¹⁾ (CL150 - 600 and NPS 8 x 6, CL900) (figure 8 should be used along with this table to determine specific limits based on valve size and trim selection)

BODY/BONNET MATERIAL ⁽²⁾	TRIM DESIGNATION FROM TABLE 5	VALVE SIZE, NPS	MATERIAL TEMPERATURE CAPABILITY			
			°C		°F	
			Min	Max	Min	Max
WCC steel	1	8 x 6 or 10 x 6 ⁽³⁾	-29	329	-20	625
		12 x 6	-29	285	-20	545
	3 3H	8 x 6 or 10 x 6 ⁽³⁾ or 12 x 6	-29	316	-20	600
			316	427	600	800
	5 5H	8 x 6, 12 x 6, 10 x 8 or 12 X 8	-29	316	-20	600
			316	427	600	800
	37	8 x 6 or 10 x 6 ⁽³⁾ or 12 x 6	-29	204	-20	400
			-29	210	-20	410
	37H	8 x 6 or 10 x 6 ⁽³⁾ 12 x 6	210	427	410	800
			210	363	410	685
LCC steel	1	8 x 6 or 10 x 6 ⁽³⁾	-29	329	-20	625
	5	8 x 6, 12 x 6, 10 x 8 or 12 x 8	-46	316	-50	600
	6	10 x 8	-46	316	-50	600
	4 and 57	8 x 6 or 10 x 6 ⁽³⁾	-46	204	-50	400
	37		-29	210	-20	410
	37H		210	343	410	650
WC9 Chrome moly steel	3	4 x 2 through 12 x 8	-29	316	-20	600
	3H		316	566	600	1050
	5	8 x 6, 12 x 6, 10 x 8 or 12 x 8	-29	316	-20	600
	5H		316	566	600	1050
	6	10 x 8	-29	316	-20	600

1. For metal trim parts only.
2. Same material also used for bonnet spacer.
3. NPS 10x6 has a valve outlet area identical to the NPS 8x6.

Table 13. Fisher CL900 EWD, EWS, and EWT Valve Body/Trim Temperature Capabilities⁽¹⁾ (figure 8 should be used along with this table to determine specific limits based on valve size and trim selection)

BODY/BONNET MATERIAL	TRIM DESIGNATION FROM TABLE 5	VALVE SIZE, NPS	MATERIAL TEMPERATURE CAPABILITY			
			°C		°F	
			Min	Max	Min	Max
WCC steel	1	8 x 6 12 x 8	-29	316	-20	600
	29, 85		-29	427	-20	800
	37	8 x 6 or 12 x 8	-29	210	-20	410
	37H		210	427	410	800
	57		-29	204	-20	400
LCC steel	1	8 x 6 only	-29	329	-20	625
	4, 37		-46	210	-50	410
	37H		210	371	410	700
	57		-29	204	-20	400
	29, 85		-46	204	-50	400
WC9 chrome moly steel	1	8 x 6	-29	316	-20	600
		12 x 8	-29	427	-20	800
	3	8 x 6	-29	427	-20	800
	3H		427	566	800	1050
	3	12 x 8	-29	427	-20	800
	3H		427	566	800	1050
	27, 87	8 x 6	-29	204	-20	400
		12 x 8	-29	343	-20	650
	29, 85	8 x 6	-29	204	-20	400
		12 x 8	-29	316	-20	600
	37	8 x 6 or 12 x 8	-29	210	-20	410
37H	210		427	410	800	
57	-29		204	-20	400	
316 SST (CF8M)	27, 87	8 x 6 or 12 x 8	-198 ⁽²⁾	343	-325 ⁽²⁾	650
	29, 85		-198 ⁽²⁾	316	-325 ⁽²⁾	600

1. For metal trim parts only.
2. May be used down to -254°C (-425°F) if manufacturing process includes Charpy impact test.

Figure 9. Typical Trim Used in Fisher EWD, EWS, and EWT NPS 8x6 CL900 Valves with Standard Cages and EWD-1, EWS-1, and EWT-1 NPS 12x8 CL900 Valves with Standard Cages (see table 14)

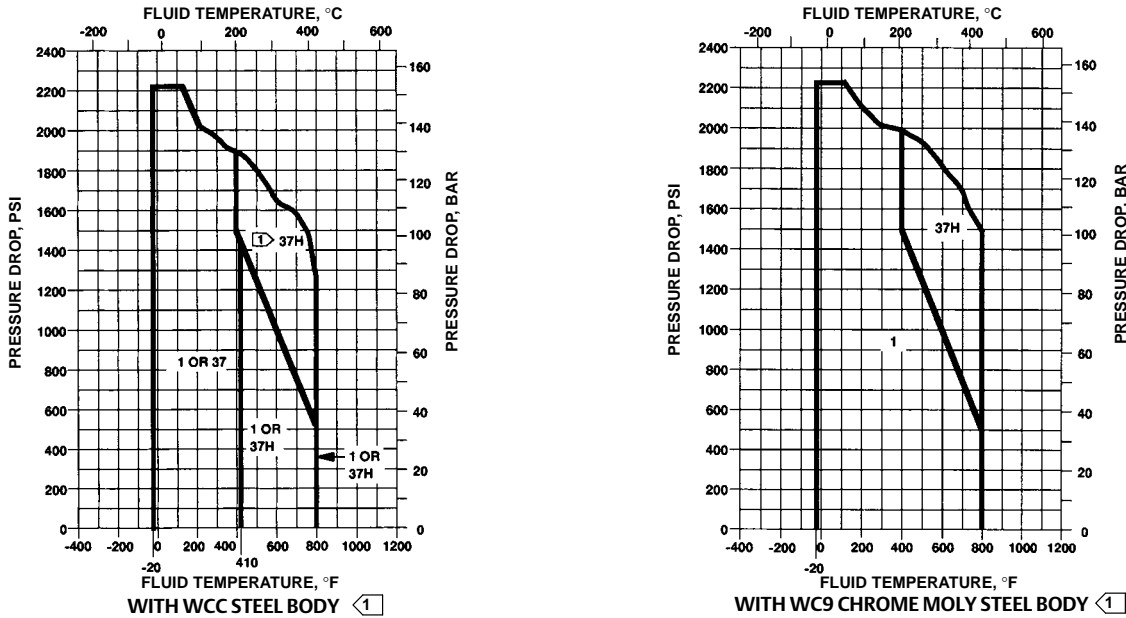

A6334-1

NOTE:

1 Do not exceed the maximum pressure and temperature for the class rating of the body material used, even through the trims shown may have higher capabilities.

Figure 10. Typical Trim Used in NPS 8x6 CL900 Fisher EWD, EWS, EWT and NPS 12x8 CL900 EWD-1, EWS-1, and EWT-1 Valves with Standard Cages (see table 14)

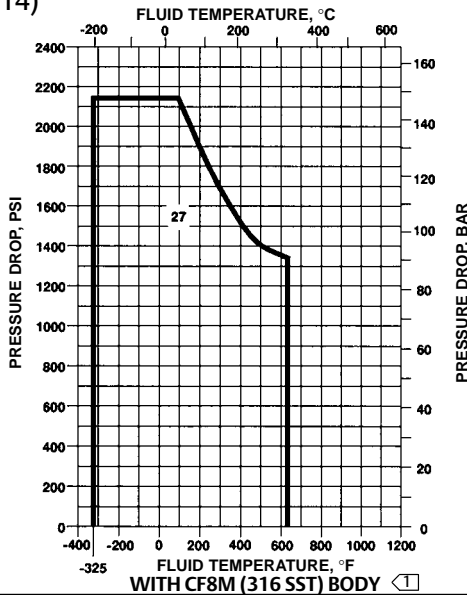

A6334-1

NOTE:

1 Do not exceed the maximum pressure and temperature for the class rating of the body material used, even through the trims shown may have higher capabilities.

Table 14. NPS 8x6 CL900 Fisher EWD, EWS, EWT and NPS 12x8 CL900 EWD-1, EWS-1, and EWT-1 Metal Trim Part Combinations Except for Valves with Whisper Trim III Cages

Trim Designation	Valve Plug	Cage	Seat Ring
1	S41600 (416 SST) heat treated	17-4 SST H900	Heat-treated CA6NM ⁽¹⁾
27	316 SST with seat and guide hard-faced with CoCr-A	316 SST with electroless nickel coating (ENC)	316 SST with seat hard-faced with CoCr-A
37 and 37H ⁽²⁾	S31600 with seat and guide hard-faced with CoCr-A	17-4 SST H900	S31600 with seat hard-faced with CoCr-A

1. CA6NM is similar to 410 SST.
2. Trim 37H has clearances for high-temperature service.

Figure 11. Detail of 2-Stage Cavitrol III Cage in CL300 or 600 Fisher EWT Valve

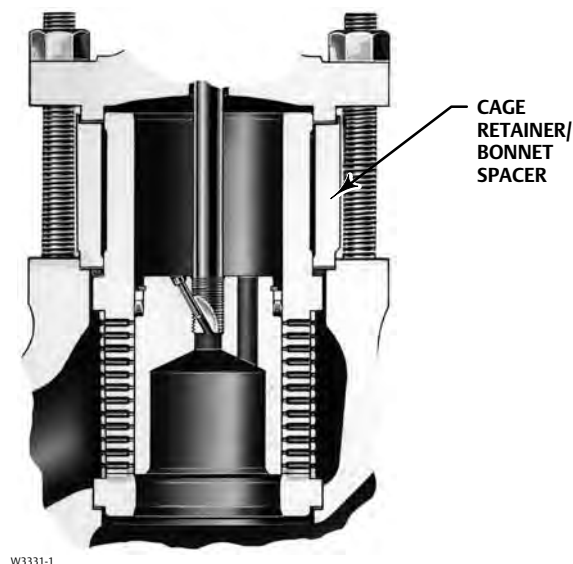
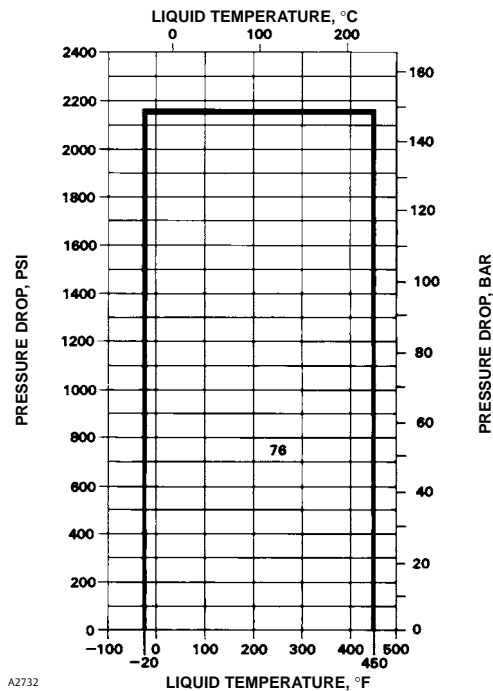

Figure 12. Typical Trim Used in Cavitrol III Cage Constructions with Steel or Stainless Steel Valves (see tables 15)



A2732

NOTE:
Do not exceed the maximum pressure and temperature for the class rating of the body material used, even though the trims shown may have higher capabilities.

Table 15. Cavitrol III⁽¹⁾ Metal Trim Part Combination

Trim Designation	Valve Plug	Cage	Cage Retainer ⁽²⁾	Seat Ring
76	Heat-treated S42000 (420 SST)	17-4 SST H900	S31600 (316 SST)	S17400 with H900 heat-treat condition

1. Available only in EWT valve.
2. Not used in NPS 12x8 or 8x6 CL900 valves.

Table 16. Cavitrol III Valve Body/Trim Temperature Capabilities

TRIM DESIGNATION FROM TABLE 15	VALVE BODY and BONNET	MATERIAL TEMPERATURE CAPABILITY				
		°C		°F		
		Min	Max	Min	Max	
76	WCC carbon steel or WC9 chrome moly steel	-29	These materials not limiting factors	-20	These materials not limiting factors	
	LCC carbon steel	-46		-50		
	S31600 (316 SST)	NPS 4x2 valve	-29	204	-20	400
		NPS 6x4 valve	-29	149	-20	300
		NPS 8x4 valve	-29	135	-20	275
		NPS 8x6 or 10x6 ⁽¹⁾ valve ⁽²⁾	-29	121	-20	250
		NPS 12x6 valve	-29	107	-20	225
NPS 12x8 valve ⁽³⁾	-29	177	-20	350		

1. NPS 10x6 has a valve outlet area identical to the NPS 8x6.
2. This valve body/trim combination not available in CL900 valve.
3. This valve body/trim combination available in all NPS 12x8 rating classes.

Figure 13. Fisher EWT Metal-Seat Valve with Whisper Trim I Cage

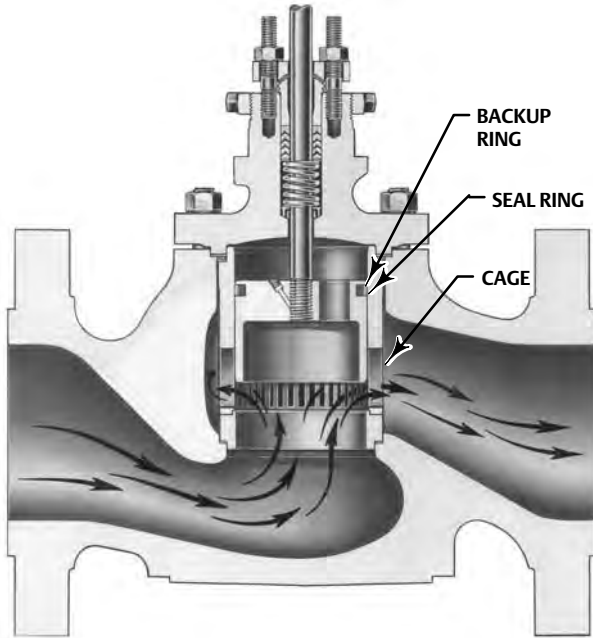

W9038

Figure 14. Fisher EWD Valve with Whisper Trim III Cage (shown with optional drain plug)

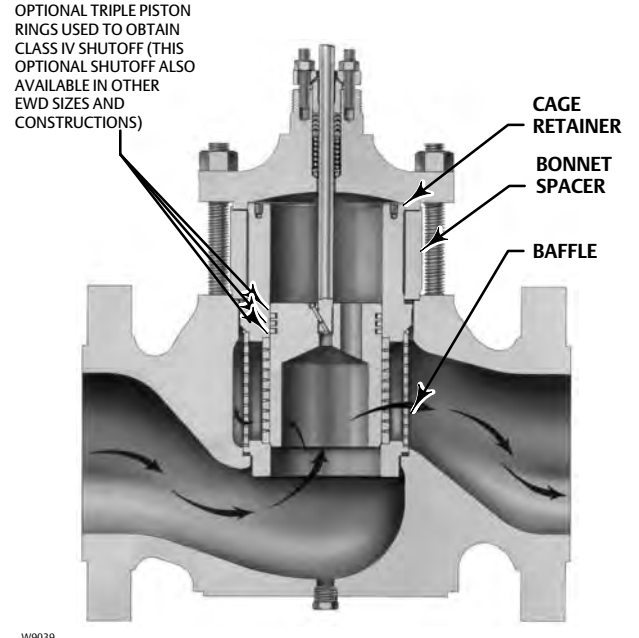

W9039

Table 17. Metal Trim Part Combinations for Fisher EWD, EWS, and EWT Valves with Whisper Trim III Cages

Trim Designation	Valve Plug	Cage	Cage Retainer	Baffle (for Level D3 Cage Only)	Seat Ring for Metal-Seat Construction	Disk Seat and Retainer for PTFE-Seat Construction	Stem
19.1 through 111.1, 177.8 and 203.2 mm (0.75 through 4.375, 7 and 8 Inch) Port Sizes							
301G	S41600	17-4 SST	--	Steel	S41600	--	S31600
301GC ⁽³⁾	S41600	17-4 SST	--	Steel	--	S31600	S31600
312G ⁽¹⁾	S31600/CoCr-A Seat & Guide	316/ENC Electroless Nickel Coated	--	S31600	R30006	--	S20910
312GC ⁽¹⁾⁽³⁾	S31600/CoCr-A Seat & Guide	316/ENC Electroless Nickel Coated	--	S31600	--	R30006/ S31600 ⁽⁹⁾	S20910
315G ⁽¹⁾	S31600/CoCr-A Seat & Guide	316 SST Chrome	--	S31600	R30006	--	S20910
315GC ⁽¹⁾⁽³⁾	S31600/CoCr-A Seat & Guide	316 SST Chrome	--	S31600	--	R30006/ S31600 ⁽⁹⁾	S20910
318G ⁽²⁾	F22/CoCr-A Seat & Guide	2.25 Cr-1 Mo Nitrided ⁽⁷⁾	--	WC9	R30006	--	S41000/ S42200 ⁽⁴⁾
306	S31803/Ultimet Seat & Guide	2205 Duplex ⁽⁶⁾ Plate	--	S31803	S31803/Ultimet	--	S31803
307G	S31600/CoCr-A Seat & Guide	17-4 SST	--	Steel	R30006	--	S31600
307GH ⁽⁵⁾	S31600/CoCr-A Seat & Guide	17-4 SST	--	Steel	R30006	--	S31600
136.5 mm (5.375 Inch) Port							
301	S17400	416 SST	WCC/ENC	Steel	S41600	--	S31600
301 A ⁽²⁾	S17400	416 SST	WCC/Nitrided	Steel	S41600	--	S31600
301 C ⁽³⁾	S17400	416 SST	WCC/ENC	Steel	--	S31600	S31600
304	S31600/CoCr-A Seat & Guide	416 SST	WCC/ENC	Steel	S31600/ CoCr-A Seat	--	S31600
312 ⁽¹⁾	S31600/CoCr-A Seat & Guide	316/ENC Electroless Nickel Coated	316/ENC Electroless Nickel Coated	S31600	R30006	--	S20910
312C ⁽¹⁾⁽³⁾	S31600/CoCr-A Seat & Guide	316/ENC Electroless Nickel Coated	316/ENC Electroless Nickel Coated	S31600	--	R30006/ S31600	S20910
315 ⁽²⁾	S31600/CoCr-A Seat & Guide	316 SST/ Electrolyzed Chrome Coat	S31600/ Electrolyzed Chrome Coat	S31600	S31600/CoCr-A	--	S31600/ S20910 ⁽⁸⁾
318 ⁽²⁾	S31600/CoCr-A Seat & Guide	2.25 Cr-1 Mo Nitrided	WC9 Nitrided ⁽⁷⁾	WC9	S31600/ CoCr-A Seat	--	S20910
306	S31803/Ultimet Seat & Guide	2205 Duplex ⁽⁶⁾ Chrome Plate	--	S31803	S31803/Ultimet	--	S31803
<p>1. NACE compatible trims meets NACE MR0175 2002, MR0175/ISO15156, MR0103. 2. Not for use with EWT construction. 3. Not for use with EWD construction. 4. Trim 318G uses S41000 stem up to 538°C (1000°F) and S42200 stem above 538°C (1000°F). 5. For high temperature service. 6. 22 Cr-5 Ni duplex stainless steel. 7. With C-seal construction use F22 alloy steel/CoCr-A/Nitrided cage material. 8. Trim 315 uses S31600 stem up to 427°C (800°F) and S20910 stem above 427°C (800°F). 9. For 8 inch port size, both disk seat and retainer use R30006.</p>							

Table 18. Valve/Trim Temperature Capabilities for Fisher EWD, EWS, and EWT Valves with Whisper Trim III Cages

VALVE/BONNET/ BONNET SPACER MATERIAL	TRIM DESIGNATION FROM TABLE 17	VALVE SIZE, NPS	MATERIAL TEMPERATURE CAPABILITY			
			°C		°F	
			Min	Max	Min	Max
19.1 through 111.1, 177.8 and 203.2 mm (0.75 through 4.375, 7 and 8 Inch) Port Size						
WCC or WC9	301G	4 x 2	-29	399	-20	750
		6 x 4	-29	316	-20	625
		8 x 4	-29	316	-20	625
		8 x 6 or 10 x 6	-29	427	-20	800
		10 x 8	-29	427	-20	800
		12 x 8	-29	427	-20	800
	301GC	4 x 2	-29	204	-20	400
		6 x 4	-29	204	-20	400
		8 x 4	-29	204	-20	400
		8 x 6 or 10 x 6	-29	204	-20	400
		10 x 8	-29	204	-20	400
		12 x 8	-29	204	-20	400
	312G	4 x 2	-29	316	-20	600
		6 x 4	-29	218	-20	425
		8 x 4	-29	218	-20	425
		8 x 6 or 10 x 6	-29	316	-20	600
		10 x 8	-29	316	-20	600
		12 x 8	-29	316	-20	600
	312GC	4 x 2	-29	204	-20	400
		6 x 4	-29	204	-20	400
		8 x 4	-29	204	-20	400
		8 x 6 or 10 x 6	-29	204	-20	400
		10 x 8	-29	204	-20	400
		12 x 8	-29	204	-20	400
	315G	4 x 2	-29	316	-20	600
		6 x 4	-29	218	-20	425
		8 x 4	-29	218	-20	425
		8 x 6 or 10 x 6	-29	316	-20	600
		10 x 8	-29	316	-20	600
		12 x 8	-29	316	-20	600
	315GC	4 x 2	-29	204	-20	400
		6 x 4	-29	204	-20	400
		8 x 4	-29	204	-20	400
		8 x 6 or 10 x 6	-29	204	-20	400
		10 x 8	-29	204	-20	400
		12 x 8	-29	204	-20	400
	318G (WCC only)	4 x 2	-29	427	-20	800
		6 x 4	-29	427	-20	800
		8 x 4	-29	427	-20	800
		8 x 6 or 10 x 6	-29	427	-20	800
		10 x 8	-29	427	-20	800
		12 x 8	-29	427	-20	800
318G (WC9 only)	4 x 2	-29	593	-20	1100	
	6 x 4	-29	593	-20	1100	
	8 x 4	-29	593	-20	1100	
	8 x 6 or 10 x 6	-29	593	-20	1100	
	10 x 8	-29	593	-20	1100	
	12 x 8	-29	593	-20	1100	

-continued-

Table 18. Valve/Trim Temperature Capabilities for Fisher EWD, EWS, and EWT Valves with Whisper Trim III Cages (continued)

VALVE/BONNET/ BONNET SPACER MATERIAL	TRIM DESIGNATION FROM TABLE 17	VALVE SIZE, NPS	MATERIAL TEMPERATURE CAPABILITY			
			°C		°F	
19.1 through 111.1, 177.8 and 203.2 mm (0.75 through 4.375, 7 and 8 Inch) Port Size						
WCC or WC9	306	4 x 2	-29	316	-20	600
		6 x 4	-29	316	-20	600
		8 x 4	-29	316	-20	600
		8 x 6 or 10 x 6	-29	316	-20	600
		10 x 8	-29	316	-20	600
	12 x 8	-29	316	-20	600	
	307G	4 x 2 through 12 x 8	-29	210	-20	410
	307GH		210	427	410	800
CF8M	301G	4 x 2	-29	149	-20	300
		6 x 4	-29	149	-20	300
		8 x 4	-29	149	-20	300
		8 x 6 or 10 x 6	-29	149	-20	300
		10 x 8	-29	149	-20	300
	12 x 8	-29	149	-20	300	
	301GC	4 x 2	-29	149	-20	300
		6 x 4	-29	149	-20	300
		8 x 4	-29	149	-20	300
		8 x 6 or 10 x 6	-29	149	-20	300
		10 x 8	-29	149	-20	300
	12 x 8	-29	149	-20	300	
	312G	4 x 2	-198	343	-325	650
		6 x 4	-198	343	-325	650
		8 x 4	-198	343	-325	650
		8 x 6 or 10 x 6	-198	343	-325	650
		10 x 8	-198	343	-325	650
	12 x 8	-198	343	-325	650	
	312GC	4 x 2	-73	204	-100	400
		6 x 4	-73	204	-100	400
		8 x 4	-73	204	-100	400
		8 x 6 or 10 x 6	-73	204	-100	400
		10 x 8	-73	204	-100	400
	12 x 8	-73	204	-100	400	
	315G	4 x 2	-198	316	-325	600
		6 x 4	-198	316	-325	600
		8 x 4	-198	316	-325	600
		8 x 6 or 10 x 6	-198	316	-325	600
		10 x 8	-198	316	-325	600
	12 x 8	-198	316	-325	600	
	315GC	4 x 2	-73	204	-100	400
		6 x 4	-73	204	-100	400
		8 x 4	-73	204	-100	400
		8 x 6 or 10 x 6	-73	204	-100	400
		10 x 8	-73	204	-100	400
	12 x 8	-73	204	-100	400	
306	4 x 2	-29	316	-20	600	
	6 x 4	-29	316	-20	600	
	8 x 4	-29	316	-20	600	
	8 x 6 or 10 x 6	-29	316	-20	600	
	10 x 8	-29	316	-20	600	
12 x 8	-29	316	-20	600		

-continued-

Table 18. Valve/Trim Temperature Capabilities for Fisher EWD, EWS, and EWT Valves with Whisper Trim III Cages (continued)

VALVE/BONNET/ BONNET SPACER MATERIAL	TRIM DESIGNATION FROM TABLE 17	VALVE SIZE, NPS	MATERIAL TEMPERATURE CAPABILITY			
			°C		°F	
136.5 mm (5.375 Inch) Port						
WCC or WC9	301	8 x 6 or 10 x 6	-29	338	-20	640
		12 x 6	-29	313	-20	595
	301A	8 x 6 or 10 x 6	-29	338	-20	640
		12 x 6	-29	313	-20	595
	301C	8 x 6 or 10 x 6	-29	204	-20	400
		12 x 6	-29	204	-20	400
	304	8 x 6 or 10 x 6	-29	343	-20	650
		12x6	-29	338	-20	640
	312	8 x 6 or 10 x 6	-29	204	-20	400
		12 x 6	-29	177	-20	350
	312C	8 x 6 or 10 x 6	-29	204	-20	400
		12 x 6	-29	177	-20	350
	315	8 x 6 or 10 x 6	-29	204	-20	400
		12 x 6	-29	177	-20	350
	318 (WCC only)	8 x 6 or 10 x 6	-29	427	-20	800
		12 x 6	-29	427	-20	800
	318 (WC9 only)	8 x 6 or 10 x 6	-29	593	-20	1100
		12 x 6	-29	593	-20	1100
306	8 x 6 or 10 x 6	-29	204	-20	400	
	12 x 6	-29	204	-20	400	
CF8M	301	8 x 6 or 10 x 6	-29	149	-20	300
		12 x 6	-29	121	-20	250
	301C	8 x 6 or 10 x 6	-29	149	-20	300
		12 x 6	-29	121	-20	250
	304	8 x 6 or 10 x 6	-29	149	-20	300
		12 x 6	-29	121	-20	250
	312	8 x 6 or 10 x 6	-29	343	-20	650
		12 x 6	-29	343	-20	650
	312C	8 x 6 or 10 x 6	-29	204	-20	400
		12 x 6	-29	204	-20	400
	315	8 x 6 or 10 x 6	-198	427	-325	800
		12 x 6	-198	427	-325	800
	306	8 x 6 or 10 x 6	-29	316	-20	600
		12 x 6	-29	316	-20	600

Figure 15. Typical Trim Used in Fisher EWD-1 Valves with Whisper Trim III Cages (see table 19)

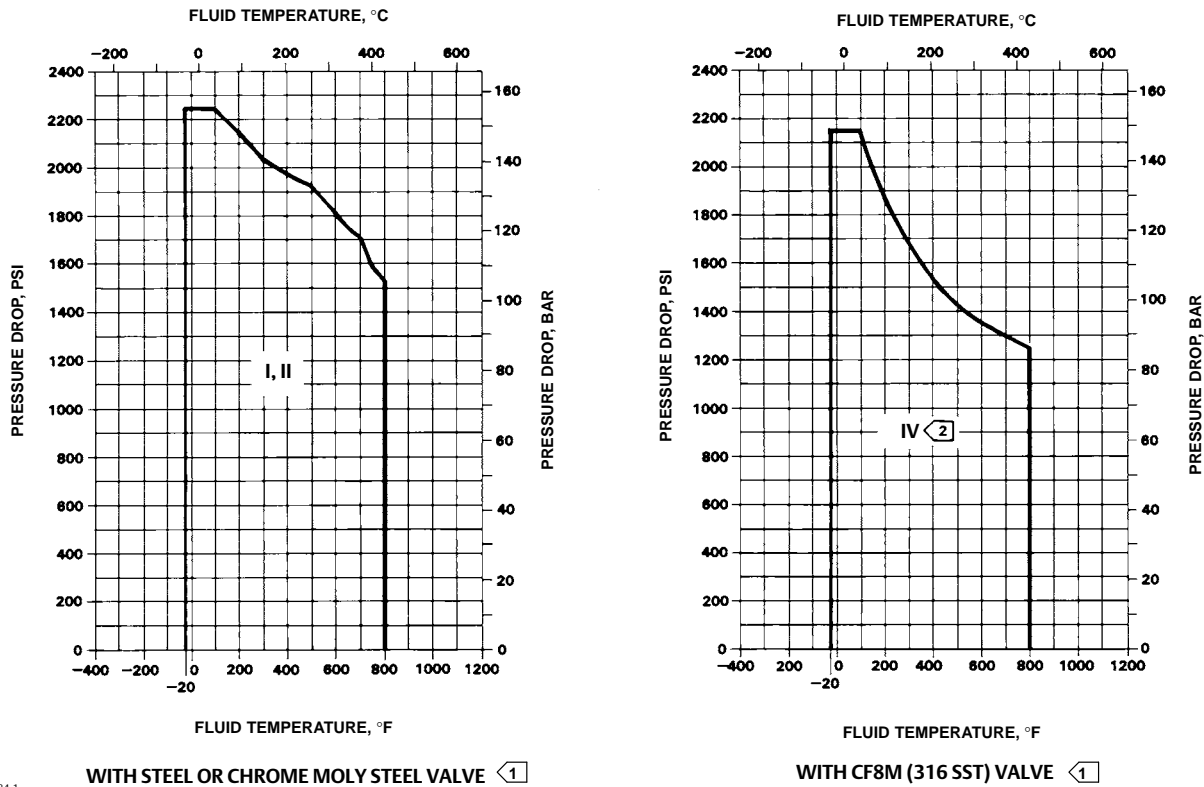

NOTE:

- ① Do not exceed the maximum pressure and temperature for the class rating of the body material used, even through the trims shown may have higher capabilities..
- ② May be used down to -101°C (-150°F) with level A, B, OR C cage, or with level D cage that has an 18-8 SST baffle.

Table 19. Fisher EWD-1 and EWT-1 Metal Trim Part Combinations for Valves with Whisper Trim III Cages

Trim Designation	Valve Plug	Cage	Seat Ring
I	Heat-treated CA6NM ⁽¹⁾	17-4 SST H1025	Heat-treated CA6NM
II	S31600 (316 SST) with seat and guide hard faced with CoCr-A		N06600 with seat hard faced with CoCr-A
IV	CF8M (316 SST) with seat and guide hard faced with CoCr-A		CF8M with seat hard faced with CoCr-A

1. CA6NM is similar to 410 SST.

Figure 16. Typical Trim Used in Fisher EWT-1 Valves with Whisper Trim III Cages (see table 19)

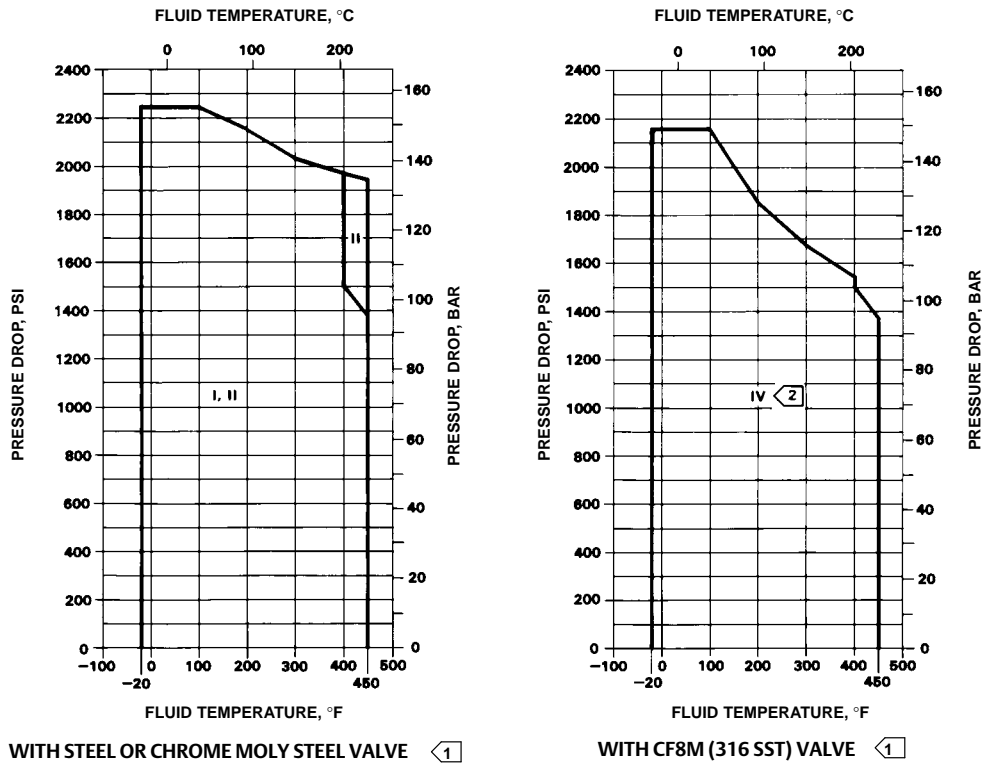

A2733-1

NOTE:

- 1 Do not exceed the maximum pressure and temperature for the class rating of the body material used, even through the trims shown may have higher capabilities.
- 2 May be used down to -101°C (-150°F) with level A, B, OR C cage, or with level D cage that has an 18-8 SST baffle.

Table 20. Materials and Temperature Limitations for Other Parts

PART		MATERIAL		MATERIAL TEMPERATURE CAPABILITY				
				°C Min	°C Max	°F Min	°F Max	
Body-to-bonnet bolting (see table 24 for NACE bolting materials and temperature limits)	WCC or WC9 valve body	Studs	Steel SA-193-B7, or steel SA-193-B7M for sour service		-29	427	-20	800
		Nuts	Steel SA-194-2H, or steel SA-194-2M for sour service					
	LCC valve body	Studs	Steel SA-193-B7		-46	371	-50	700
		Nuts	Steel SA-194-2H					
	WC9 valve body	Studs	Steel SA-193-B16		-29	593	-20	1100
		Nuts	Steel SA-194-7					
	CF8M (316 SST) valve body	Studs	Steel SA-193-B7		-48	427	-55	800
		Nuts	Steel SA-194-2H					
		Studs	Steel SA-193-B7M for sour service		-46	427	-50	800
		Nuts	Steel SA-194-2HM for sour service		-46	343	-50	650
		Studs	304 SST SA-320-B8		-254	38	-425	100
		Nuts	304 SST SA-194-8					
		Studs	316 SST SA-193-B8M (strain hardened)		-198 ⁽¹⁾	427	-325 ⁽¹⁾	800
		Nuts	316 SST SA-194-8M					
Disk (all soft-seat constructions)		PTFE		-73	204	-100	400	
EWD piston ring	Std. for NPS 4x2 thru 12x6		Graphite (FMS 17F27)		-46 ⁽²⁾	427	-50 ⁽²⁾	800
	Std. for NPS 10x8 and 12x8; optional for NPS 4x2 thru 12x6		Graphite FMS 17F39	Oxidizing service—all sizes	-46 ⁽²⁾	538	-50 ⁽²⁾	1000
			Nonoxidizing service	NPS 12x8 CL900 and 12x8 CL600 and smaller	-46 ⁽²⁾	593	-50 ⁽²⁾	1100
Standard NPS 4x2 through 12x6 EWT valve plug seal (except valve with Cavitrol III cage)	Backup ring	Fluorocarbon ⁽³⁾		-18	204	0	400	
		Ethylene-propylene ⁽⁴⁾		-40	232	-40	450	
		Nitrile ⁽⁵⁾	For use with hydrocarbons		-34	71	-30	160
			For use with other fluids		-34	93	-30	200
	Seal ring	Carbon-filled PTFE		-73	232	-100	450	
Spring-loaded EWT or EWT-1 valve plug seal ⁽⁶⁾ (standard for NPS 10x8 and 12x8 valve regardless of cage and all NPS 4x2 through 12x6 valves with Cavitrol III cage; optional in NPS 4x2 through 12x6 valves with other than Cavitrol III cages)	Backup ring	S41600 (416 SST)		-29	427	-20	800	
	Retaining ring	S30200 (302 SST)		-254	593	-425	1100	
	Seal ring	PTFE with N10276 Spring		-73	232 ⁽¹⁰⁾	-100	450 ⁽¹⁰⁾	
	Anti-extrusion rings	PEEK (PolyEtherEtherKetone)	 ⁽¹¹⁾ ⁽¹¹⁾	
Valve plug stem and pin		S31600 (316 SST) (S20910, NACE Std)		-198 ⁽¹⁾	593	-325 ⁽¹⁾	1100	
Load ring (NPS 10x8 and 12x8 EWD, EWS, and EWT only)	CB7CU-1 (17-4PH SST)		-102	316	-150	600		
	N07718 ⁽⁷⁾		-254	593	-425	1100		
	N05500 ⁽⁷⁾		-240	260	-400	500		
Seat ring, bonnet and cage gaskets	FGM (standard)		-198	593	-325	1100		
	PTFE-coated N04400		-73	149	-100	300		
Spiral wound gaskets		N06600 ⁽⁷⁾ /laminated graphite FGM (standard)		-198	593	-325	1100	
Packing (temperatures shown are material temperature capabilities)	PTFE V-ring		-40	232	-40	450		
	PTFE/composition		-73	232	-100	450		
	Graphite ribbon/filament		-198	538 ⁽⁹⁾	-325	1000 ⁽⁹⁾		
	Graphite ribbon for high-temperature oxidizing service		371	649	700	1200		
Packing flange, studs and nuts when used with standard bonnet		S31600		-198 ⁽¹⁾	593	-325 ⁽¹⁾	1100	
Packing follower, and packing spring ⁽⁸⁾ or lantern ring		S31600		-198 ⁽¹⁾	593	-325 ⁽¹⁾	1100	
Packing box ring when used with standard bonnet		S31600		-198 ⁽¹⁾	593	-325 ⁽¹⁾	1100	
Extension bonnet bushing	Trims 1 and 4	S41600		-29	427	-20	800	
	Other trims	S31600		-198 ⁽¹⁾	593	-325 ⁽¹⁾	1100	

1. May be used down to -254°C (-425°F) if manufacturing process includes Charpy impact test.
 2. This minimum is due to thermal expansion differential between piston ring and cage at low temperatures.
 3. For high-temperature air, hydrocarbons, and certain other chemicals and solvents, but cannot be used with ammonia, steam, or hot water.
 4. Has excellent moisture resistance to hot water and steam and may be used with most fire-resistant hydraulic oils, but cannot be used with petroleum-based fluids and other hydrocarbons.
 5. Cannot be used with fire-resistant hydraulic oils.
 6. May be used to increase hot water service capability to 232°C (450°F).
 7. This material may be used for cyclic temperatures or those above 232°C (450°F).
 8. Spring is used only with single PTFE V-ring packing; lantern ring replaces spring in other packings.
 9. Except 371°C (700°F) on oxidizing service.
 10. If used with PEEK anti-extrusion rings, PTFE/carbon seal ring may be used in temperatures up to 316°C (600°F) for non-oxidizing service or up to 260°C (500°F) for oxidizing service.
 11. These materials not limiting factors.

Table 21. Port Diameters, Valve Plug Travel, and Stem and Yoke Boss Diameters^(1,9)

VALVE SIZE, NPS	PORT DIAMETER		MAX VALVE PLUG TRAVEL		STEM AND YOKE BOSS DIAMETERS								CAGE STYLE	
					Standard				Optional					
					Stem		Yoke Boss		Stem		Yoke Boss			
					mm	Inch	mm	Inch	mm	Inch	mm	Inch		
4 x 2	33.3	1.3125	31.8	1.25	12.7	1/2	71.4	2 13/16	19.1	3/4	90.5	3 9/16	Whisper Trim III only	
	58.7	2.3125	34.9	1.375										
	58.7	2.3125	28.6	1.125										
6 x 4, 8 x 4	111	4.375	50.8	2	12.7	1/2	71.4	2 13/16	19.1	3/4	90.5	3 9/16	Quick-opening, linear, Eq.%, Whisper Trim I, Whisper Trim III, or Cavitrol ⁽¹⁾	
	87.3	3.438	50.8	2	12.7	1/2	71.4	2 13/16	25.4 or 31.8	1 or 1 1/4	127	5		
8 x 6, 10 x 6 ⁽⁸⁾ , or 12 x 6			178	7	50.8	2	19.1	3/4	90.5	3 9/16	25.4 or 31.8	1 or 1 1/4	127	5
	76.2	3			19.1	3/4	90.5	3 9/16	---			Cavitrol only ⁽¹⁾		
8 x 6, 10 x 6 ⁽⁸⁾ , or 12 x 6	178	7	102 ⁽²⁾	4 ⁽²⁾	19.1	3/4	90.5	3 9/16	---			Whisper Trim I		
8 x 6, 10 x 6 ⁽⁸⁾	178	7	76.2	3	19.1	3/4	90.5	3 9/16	25.4 or 31.8	1 or 1 1/4	127	5	Whisper Trim III only	
	178	7	102	4										
	137	5.375	127 ⁽³⁾	5 ⁽³⁾										
12 x 6	137	5.375	165 ⁽³⁾	6.5 ⁽³⁾										
10 x 8	203	8	76.2	3	19.1	3/4	90.5	3 9/16	25.4 or 31.8	1 or 1 1/4	127	5	Quick-opening, linear, or Eq. %	
			152	6									Whisper Trim III only	
	178	7	152	6										
12 x 8	CL300 ⁽⁴⁾ or CL600 ⁽⁴⁾	203	8	76.2	3	19.1	3/4	90.5	3 9/16	25.4 or 31.8	1 or 1 1/4	127	5	Quick-opening, linear, or Eq. %
				152	6									Whisper Trim III only
				178	7									
	CL900	203	8	76.2	3	25.4	1	127	5	19.1	3/4	90.5	3 9/16	Quick-opening, linear, or Eq. %
						31.8	1 1/4			25.4	1	127H ⁽⁵⁾	5H ⁽⁵⁾	
						31.8	1 1/4			---				
197 ⁽⁶⁾	7.75 ⁽⁶⁾	152	6	31.8	1 1/4	127	5	---			Whisper Trim III only			
171 ⁽⁷⁾	6.75 ⁽⁷⁾													

1. Except for Cavitrol III cages, which are covered in separate documentation
2. Bonnet spacer required. This travel available only in CL300 or 600 EWD or EWT
3. Bonnet spacer required for EWD or EWT valve, but not EWS valve
4. Bonnet spacer required for EWD, EWS, and EWT valve.
5. H indicates heavy actuator-to-bonnet bolting is required
6. Port diameter for level A, B, or C cage.
7. Port diameter for level D cage
8. NPS 10x6 has a valve outlet area identical to the NPS 8x6.
9. Refer Fisher Bulletin 80.1:010 Whisper Trim III ([D100191X012](#)) for more information on Whisper Trim III.

Figure 17. Typical ENVIRO-SEAL and HIGH-SEAL Packing Systems

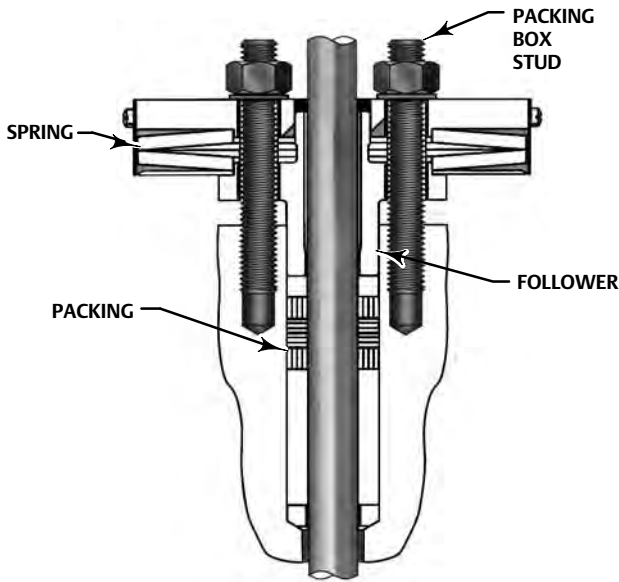

W8533-1

TYPICAL HIGH-SEAL PACKING SYSTEM WITH GRAPHITE ULF PACKING

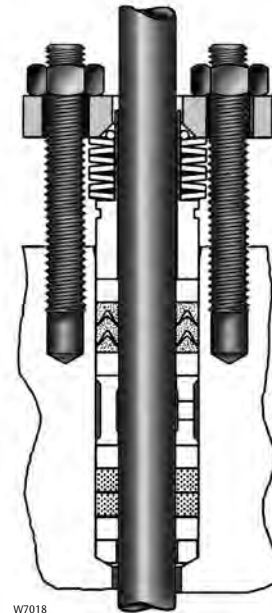

W7018

TYPICAL ENVIRO-SEAL PACKING SYSTEM WITH DUPLEX PACKING

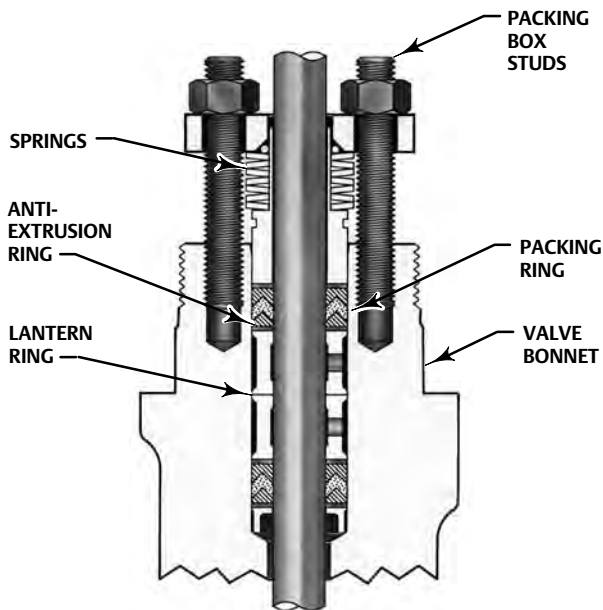

W5803-3

TYPICAL ENVIRO-SEAL PACKING SYSTEM WITH PTFE PACKING

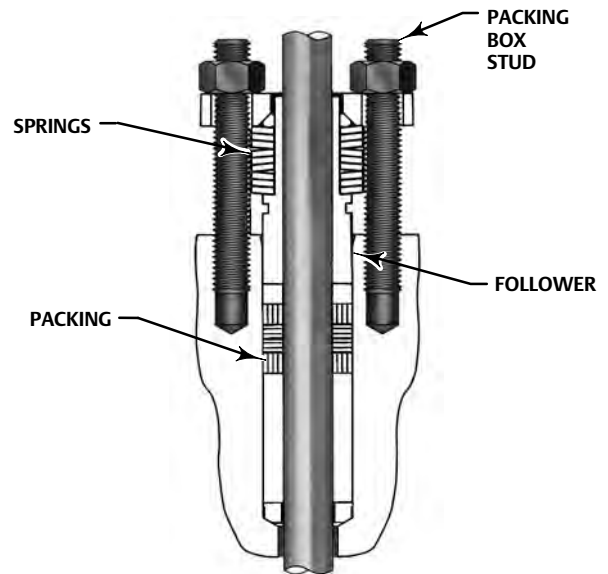

W8532-1

TYPICAL ENVIRO-SEAL PACKING SYSTEM WITH GRAPHITE ULF PACKING

Table 22. Approximate Weights

END CONNECTION		VALVE SIZE, NPS															
		4 x 2		6 x 4		8 x 4		8 x 6		10 x 6 ⁽¹⁾		12 x 6		10 x 8		12 x 8	
		kg	Lb	kg	Lb	kg	Lb	kg	Lb	kg	Lb	kg	Lb	kg	Lb	kg	Lb
CL300		84	185	150	330	234	515	284	625	348	765	500	1102	567	1250	653	1440
CL600	Flanged	100	220	195	430	272	600	308	680	431	950	721	1590	744	1640	857	1890
	Buttwelding	61	135	122	270	177	390	272	600	380	839	526	1160	512	1130	658	1450
CL900	Flanged	---						612	1350	---						1361	3000
	Buttwelding	---						454	1000	---						1293	2850

1. NPS 10x6 has a valve outlet area identical to the NPS 8x6.

Figure 18. ENVIRO-SEAL Bellows Seal Bonnet



W5852-1

Table 23. Bonnet Selection Guidelines

BONNET STYLE (CL300, 600) ⁽¹⁾	PACKING	IN-BODY PROCESS TEMPERATURE LIMITS ⁽²⁾	
		°C	°F
Plain Bonnet ■ Standard for NPS 2, 4, and 6 nominal trim sizes ■ Standard for NPS 10x8 and 12x8 valves (in cast iron, WCC). Not available in S31600	PTFE V-ring	-18 to 232	0 to 450
	PTFE/composition	-18 to 232	0 to 450
	Graphite ribbon/filament	-18 to maximum shown in table 20	0 to maximum shown in table 20
Style 1 Cast Extension Bonnet ■ Optional for NPS 2, 4, and 6 nominal trim sizes ■ Standard for NPS 10x8 and 12x8 valves (in S31600). Optional in WCC; not available in cast iron	PTFE V-ring	-46 to 427	-50 to 800
	PTFE/composition		
	Graphite ribbon/filament	to maximum shown in table 20	to maximum shown in table 20
Style 2 Cast Extension Bonnet ■ Optional for NPS 2, 4, and 6 nominal trim sizes ■ Optional for NPS 10x8 and 12x8 valves (in WCC). Not available in cast iron or S31600	PTFE V-ring	-101 to 427	-150 to 800
	PTFE/Composition		
	Graphite ribbon/filament	to maximum shown in table 20	to maximum shown in table 20
ENVIRO-SEAL Bellows Seal Bonnet ■ Optional for NPS 2, 4, 6, and 8 nominal trim sizes. Maximum travel is 2 inches	PTFE	For exceptional stem sealing capabilities. See Bulletin 59.1:070, ENVIRO-SEAL Bellows Seal Bonnets, (D101641X012) for pressure/temperature ratings.	For exceptional stem sealing capabilities. See Bulletin 59.1:070, ENVIRO-SEAL Bellows Seal Bonnets, (D101641X012) for pressure/temperature ratings.
	Graphite ULF		

1. For CL900 valve bodies, only the plain bonnet is available. Consult your [Emerson sales office](#) for assistance if application conditions indicate the need for an extension bonnet for a CL900 valve body.
 2. These in-body process temperatures assume an outside, ambient temperature of 21°C (70°F) and no insulation on the bonnet. When using any packing at low process temperatures, a cast extension bonnet may have to be used to prevent packing damage which could result from the formation of valve stem frost. Material selection for trim and other components will also be limiting factors.

Table 24. Bolting Materials and Temperature Limits for Bolting Compliance with NACE MR0175-2002, NACE MR0175/ISO 15156, and NACE MR0103. Environmental restrictions may apply.

VALVE BODY MATERIAL		BOLTING MATERIAL		TEMPERATURE CAPABILITIES			
				°C		°F	
				Min	Max	Min	Max
Non-exposed bolting (Standard)							
WCC	Studs	Steel SA-193-B7		-7	232	20	450
	Nuts	Steel SA-194-2H					
	Studs	Steel SA-193-B7		232	427	450	800
	Nuts	Steel SA-194-2H lubricated					
CF8M (316 SST)	Studs	Steel SA-193-B7 or B8M strain hardened		-48	232	-55	450
	Nuts	Steel SA-194-2H or 8M					
	Studs	Steel SA-193-B8M strain hardened or B7		232	427	450	800
	Nuts	Steel SA-194-8M lubricated or 2H lubricated					
Exposed bolting (Optional) Requires Derating of Valve⁽²⁾ When These Body-to-Bonnet Bolting Materials are Used							
WCC and CF8M	Studs	Steel SA-193-B7M		-46 ⁽¹⁾	232	-50 ⁽¹⁾	450
	Nuts	Steel SA-194-2HM					
	Studs	Steel SA-193-B7M		232	427	450	800
	Nuts	Steel SA-194-2HM lubricated					

1. Minimum temperature is -29°C (-20°F) with WCC valve body material.
 2. Derating is not required for CL300 valves. Derating may be required for valves rated at CL600 or 900. Emerson sales office for assistance in determining the derating of valves when these body-to-bonnet bolting materials are used.

Table 25. Dimensions

VALVE SIZE, NPS	A									G (MAX)	
	Class, End Connection Style ⁽¹⁾									CL150, 300, and 600	CL900
	CL150			CL300		CL600		CL900			
	RF	RF	RTJ	RF, BW	RTJ	RF	RTJ	BW			
mm											
4 x 2	352	368 ⁽²⁾	384	394 ⁽²⁾	397	---	---	---	108	---	
6 x 4	451	473 ⁽²⁾	489	508 ⁽²⁾	511	---	---	---	135	---	
8 x 4	543	568 ⁽²⁾	584	610 ⁽²⁾	613	---	---	---	176	---	
8 x 6	543	568 ⁽²⁾	584	610 ⁽²⁾	613	914 ⁽³⁾	917	972	183	198	
10 x 6 ⁽⁴⁾	603	603	619	625	629	---	---	---	183	---	
12 x 6	737	775 ⁽²⁾	791	819 ⁽²⁾	822	---	---	---	254	---	
10 x 8	673	708 ⁽²⁾	724	752 ⁽²⁾	756	---	---	---	275	---	
12 x 8	737	775 ⁽²⁾	791	819 ⁽²⁾	822	902	905	953	356	356	
Inch											
4 x 2	13.88	14.50 ⁽²⁾	15.12	15.50 ⁽²⁾	15.62	---	---	---	4.25	---	
6 x 4	17.75	18.62 ⁽²⁾	19.25	20.00 ⁽²⁾	20.12	---	---	---	5.31	---	
8 x 4	21.38	22.38 ⁽²⁾	23.00	24.00 ⁽²⁾	24.12	---	---	---	6.94	---	
8 x 6	21.38	22.38 ⁽²⁾	23.00	24.00 ⁽²⁾	24.12	36.00 ⁽³⁾	36.12	38.25	7.19	7.81	
10 x 6 ⁽⁴⁾	23.75	23.75	24.38	24.62	24.75	---	---	---	7.19	---	
12 x 6	29.00	30.50 ⁽²⁾	31.12	32.25 ⁽²⁾	32.38	---	---	---	10.00	---	
10 x 8	26.50	27.88 ⁽²⁾	28.50	29.62 ⁽²⁾	29.75	---	---	---	10.81	---	
12 x 8	29.00	30.50 ⁽²⁾	31.12	32.25 ⁽²⁾	32.38	35.50	35.62	37.50	14.00	14.00	

1. End connection style abbreviations: RF - Raised Face, RTJ - Ring Type Joint, BW - Butt welding.
 2. Per ISA 75.08.01.
 3. Per ISA 75.08.06.
 4. NPS 10x6 has a valve outlet area identical to the NPS 8x6.

Table 26. Dimensions

VALVE SIZE, DN	A					
	PN, End Connection Style ⁽¹⁾					
	PN 16, RF	PN 25, RF	PN 40, RF	PN 63, RF	PN 100, RF	PN 160, RF
	mm					
100 x 50	---	---	---	430	430	---
150 x 100	480	480	480	550	550	---
200 x 100	600	600	600	650	650	---
200 x 150	---	600	600	650	650	---
300 x 150	850	850	850	900	900	---
250 x 200	---	---	---	---	---	---
300 x 200	---	850	850	900	900	900

1. End connection style abbreviations: RF - Raised Face.

Figure 19. Dimensions (also see tables 25, 26, 27, and 28)

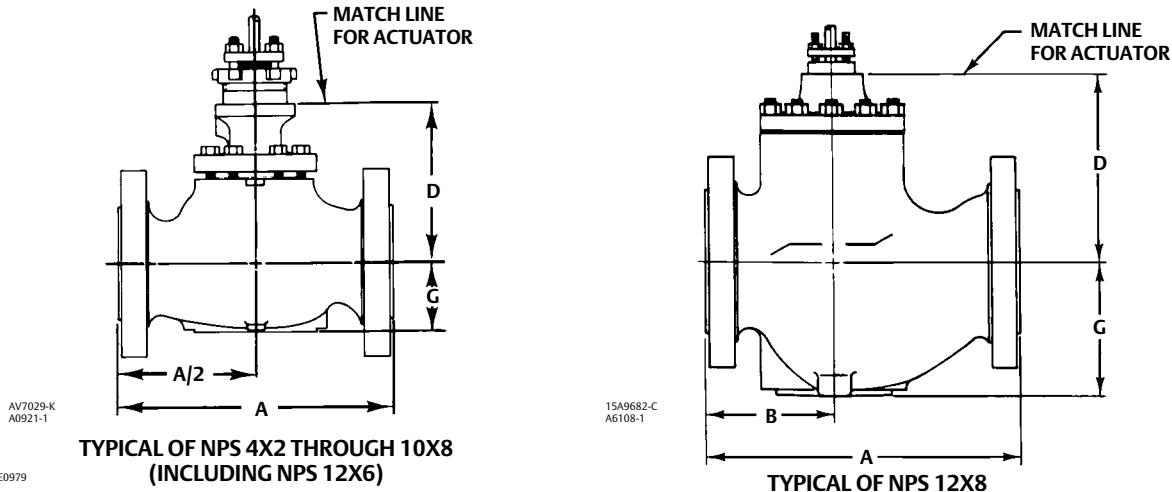

Table 27. Dimensions (Dimension B for 12 x 8 Valve Sizes)

VALVE SIZE, NPS	Class, End Connection Style ⁽¹⁾							
	CL150	CL300		CL600		CL900		
	RF	RF	RTJ	RF, BW	RTJ	RF	RTJ	BW
	mm							
12 x 8	292	311	319	333	335	397	398	422
	Inch							
12 x 8	11.50	12.25	12.56	13.12	13.18	15.63	15.69	16.63
1. End connection style abbreviations: RF - Raised Face, RTJ - Ring Type Joint, BW - Buttwelding.								

Table 28. Dimensions (Dimension D for All Valve Sizes)

CAGE STYLE	BONNET	VALVE SIZE, NPS	STEM DIA									
			12.7 mm (1/2 Inch)		19.1 mm (3/4 Inch)				25.4 mm (1 Inch) or 31.8 mm (1-1/4 Inch)			
					CL900 Only		All Except CL900		CL300 and 600		CL900	
			mm	Inch	mm	Inch	mm	Inch	mm	Inch	mm	Inch
All except Cavitrol III or Whisper Trim III	Plain	4 x 2	216	8.50	---	---	213	8.38	---	---	---	---
		6 x 4	257	10.12	---	---	254	10.00	300	11.81	---	---
		8 x 4	259	10.19	---	---	256	10.06	302	11.88	---	---
		8 x 6, 10 x 6 ⁽³⁾	287	11.31	409	16.12	287	11.31	332	13.06	464	18.25
		12 x 6	356	14.00	---	---	356	14.00	400	15.75	---	---
		10 x 8	---	---	---	---	375	14.75	---	---	---	---
		12 x 8	---	---	584	23.00	411	16.19	---	---	608	23.94
	Style 1 Extension	4 x 2	318	12.50	---	---	322	12.69	---	---	---	---
		6 x 4	359	14.12	---	---	363	14.31	432	17.00	---	---
		8 x 4	360	14.19	---	---	365	14.38	433	17.06	---	---
		8 x 6, 10 x 6 ⁽³⁾	---	---	---	---	394	15.50	464	18.25	---	---
		12 x 6	---	---	---	---	462	18.19	532	20.94	---	---
		10 x 8	---	---	---	---	421	16.56	449	17.69	---	---
		12 x 8	---	---	---	---	457	18.00	486	19.12	---	---
	Style 2 Extension	4 x 2	516	20.31	---	---	513	20.19	---	---	---	---
		6 x 4	562	22.12	---	---	554	21.81	595	23.44	---	---
		8 x 4	564	22.19	---	---	556	21.88	597	23.50	---	---
		8 x 6, 10 x 6 ⁽³⁾	---	---	---	---	579	22.81	---	---	---	---
		10 x 8	---	---	---	---	621	24.44	---	---	---	---
		12 x 6	---	---	---	---	648	25.50	---	---	---	---
		12 x 8	---	---	---	---	---	---	---	---	---	---
	ENVIRO-SEAL bellows seal bonnet	4 x 2	435	17.12	---	---	---	---	---	---	---	---
		6 x 4	576	22.69	---	---	576	22.69	---	---	---	---
		8 x 4	578	22.75	---	---	578	22.75	---	---	---	---
10 x 8		---	---	---	---	703	27.69	---	---	---	---	
8 x 6, 10 x 6 ⁽³⁾		---	---	---	---	608	23.94	---	---	---	---	
12 x 6		---	---	---	---	676	26.62	---	---	---	---	
12 x 8		---	---	---	---	---	---	---	---	---	---	
Cavitrol III	Plain	4 x 2	252	9.94	---	---	249	9.81	---	---	---	---
		6 x 4	346	13.62	---	---	343	13.50	389	15.31	---	---
		8 x 4	348	13.69	---	---	344	13.56	---	---	---	---
		8 x 6, 10 x 6 ⁽³⁾	403	15.88	---	---	403	15.88	---	---	---	---
		10 x 8 ⁽¹⁾	---	---	---	---	375	14.75	425	16.75	---	---
		10 x 8 ⁽²⁾	---	---	---	---	511	20.12	560	22.06	---	---
		12 x 6	480	18.88	---	---	480	18.88	---	---	---	---
Whisper Trim III	Plain	4 x 2	4 x 2	216	8.50	---	---	213	8.38	---	---	---
		6 x 4	6 x 4	257	10.12	---	---	254	10.00	300	11.81	---
		8 x 4	8 x 4	259	10.19	---	---	256	10.06	302	11.88	---
		8 x 6, 10 x 6 ⁽³⁾	287	11.31	409	16.12	399	15.69	443	17.44	464	18.25
		12 x 6	356	14.00	---	---	503	19.81	548	21.56	---	---
		10 x 8	---	---	---	---	504	19.83	---	---	---	---
		12 x 8	---	---	---	---	---	---	---	---	---	---

1. One-stage trim.
2. Two-stage trim.
3. NPS 10x6 has a valve outlet area identical to the NPS 8x6.

Neither Emerson, Emerson Automation Solutions, nor any of their affiliated entities assumes responsibility for the selection, use or maintenance of any product. Responsibility for proper selection, use, and maintenance of any product remains solely with the purchaser and end user.

Fisher, easy-e, Cavitrol, Whisper Trim, ENVIRO-SEAL, and WhisperFlo are marks owned by one of the companies in the Emerson Automation Solutions business unit of Emerson Electric Co. Emerson Automation Solutions, Emerson, and the Emerson logo are trademarks and service marks of Emerson Electric Co. All other marks are the property of their respective owners.

The contents of this publication are presented for informational purposes only, and while every effort has been made to ensure their accuracy, they are not to be construed as warranties or guarantees, express or implied, regarding the products or services described herein or their use or applicability. All sales are governed by our terms and conditions, which are available upon request. We reserve the right to modify or improve the designs or specifications of such products at any time without notice.

Emerson Automation Solutions
Marshalltown, Iowa 50158 USA
Sorocaba, 18087 Brazil
Cernay, 68700 France
Dubai, United Arab Emirates
Singapore 128461 Singapore

www.Fisher.com

